

RECLAIMED

SUMMARY OF CHANGES

Authorization #1 - Amendments Effective March 31, 2012

Chapter Six (6)	Section Name	Amendment Description
Section 650-B Approved Materials Checklist	Category 1 of 9: Valves and Accessories	Added Clow Series F-6100 for Gate Valves 12-inch and Smaller (Resilient Seated Only)
Section 650-B Approved Materials Checklist	Category 1 of 9: Valves and Accessories	Added Clow Series F-6114 for Tapping Valves (Resilient Seated Only)
Section 650-B Approved Materials Checklist	Category 2 of 9: Service Materials	Listed approved meter box providers (plastic lids), Carson Polyplastic and DFW Alliance
Section 650-B Approved Materials Checklist	Category 3 of 9: Service Materials	Removed Freedom Plastics from Approved Manufacturer (Out of Business) for PVC Pantone 522-C Purple) 4" - 12" Pipe and 16" and larger Pipe
Section 650-B Approved Materials Checklist	Category 4 of 9: Pipe Fittings	Added JCM Series 432 for Tapping Sleeves (MJ on cast iron, DIP, PVC-900, etc.)
Section 650-C:	Reclaimed Water System Hydrostatic Pressure Test Report (PVC and DIP)	Updated/corrected maximum allowable leakage equation

Authorization #2 - Amendments Effective December 15, 2012

Chapter Six (6)	Section Name	Amendment Description
Section 610:	Part 6 - Design B - Pressure	Clarified Reclaimed Water design pressure for master metered systems
Section 610:	Part 6 - Design - C. Diameter	Clarified Reclaimed Water design variation with reference to the diameter for main size
Section 610:	Part 6 - Design - E. Design Friction Losses	Clarified Reclaimed Water through mains Design Friction Losses formulas
Section 610:	Part 6 - Design - F. Design Pressure and Restraint 1-3	Clarified Reclaimed Water Design Pressure and Restraint for water mains and fittings
Section 610:	Part 6 - Design - G. Dead Ends	Clarified Reclaimed Water design for increased reliability of service for Dead Ends
Section 610:	Part 6 - Design - H. Valves	Clarified Reclaimed Water design for valves on water mains

RECLAIMED
SUMMARY OF CHANGES

Chapter Six (6)	Section Name	Amendment Description
Section 610:	Part 6 - Design - I. Combination Air/Vacuum Release Valves	Clarified Reclaimed Water design for combination air/vacuum release valves
Section 610:	Part 6 - Design - J.	Deletion of Control Valve information under Reclaimed Water design
Section 610:	Part 6 - Design - K. Booster Pumps	Clarified Reclaimed Water guideline of Private in-line Booster Pump
Section 610:	Part 6 - Design - L. Restrained Joints 2.	Clarified Reclaimed Water design for Restrained Joints
Section 610:	Part 6 - Design - O. Signage and Public Notice	Corrected Letter on Bulleted list
Section 610:	Part 7 - System Connection and Service Connections - A.	Clarified Reclaimed Water System Connection and Service Connections installation
Section 610:	Part 8 – Water Metering A. General - 1-7	Clarified General Reclaimed Water Service Connection specs with Numbered list of requirements
Section 610:	Part 8 – Water Metering, E Meter Installation	Clarified Meter Installation specs for Reclaimed Water Service Connection
Section 610:	Part 9 - Part 12	Inserted title names for specific parts of Chapter 6 Section 610
Section 610:	Part 13 - Approved Uses of Reclaimed Water B. Other Approved Uses of Reclaimed Water	Created numbered list of Other Approved Uses of Reclaimed Water
Section 610:	Part 14 - Part 19.06	Inserted title names and numbered list for specific parts of Chapter 6 Section 610
Section 650A:	Testing and Inspection for Acceptance B., 5. 2. Procedure for Leakage Test	Updated/corrected maximum allowable leakage equation
Section 650A:	Testing and Inspection for Acceptance B., 5. 2. Procedure for Leakage Test	Clarified when reclaimed water distribution system may be activated
Section 650A:	4.05 - Automatic Air Release Valve Assemblies	Deleted reference to automatic blow off valves on reclaimed systems
Section 650:	Standard Drawings TOC	Inserted reference for RW-03
Standard Drawings:	RW-03: Reclaimed Water Master Meter Assembly (Larger than 2 inch)	Inserted Drawing for Reclaimed Water Master Meter Assembly

RECLAIMED

SUMMARY OF CHANGES

Authorization #3 - Amendments Effective May 22, 2013

Chapter Six (6)	Section Name	Amendment Description
Section 611	Reclaimed Water SCADA Specifications	Added NEW Section 611 Reclaimed Water Facilities SCADA Specifications and iFix schematics

Authorization #4 - Amendments Effective November 17, 2013

Chapter Six (6)	Section Name	Amendment Description
Section 650-B Approved Materials Checklist	Category 1 of 9: Valves and Accessories	Clarified VM-38 and VM-45 for plant, facility use only. Added VM200C (combo valve) -- also for plant, facility use only.
Section 650-B Approved Materials Checklist	Category 1 of 9: Valves and Accessories	Val-matic 2000 butterfly valves authorized for use (16" and larger)

Authorization #5 - Amendments Effective September 10, 2014

Chapter Six (6)	Section Name	Amendment Description
Section 650-B Approved Materials Checklist	Categories 2 and 3 of 9: Service Materials, Pipe Materials	Change "Tracer" to "Locating"
Section 650-B Approved Materials Checklist	Category 2 of 9: Service Materials	Updated meter box specification to reference cast iron reader
Section 650-B Approved Materials Checklist	Category 2 of 9: Service Materials	Added Apollo brand dual check for potable meters (3/4" and 1") (Cat 2)

Authorization #6 - Amendments Effective October 3, 2015

Chapter Six (6)	Section Name	Amendment Description
Section 650-B Approved Materials Checklist	Category 1 of 9: Valves and Accessories	Corrected Water Plus ARV Part No. to 131632
Section 650-B Approved Materials Checklist	Category 1 of 9: Valves and Accessories	Deleted all Blow Off Valve Manufacturers, Part Numbers and Comments (Not permitted on reclaimed)
Section 650-B Approved Materials Checklist	Category 1 of 9: Valves and Accessories	Added Team Industrial Products for Insertion Valve MJ/Ductile Iron RWGV (New valve type)
Section 650-B Approved Materials Checklist	Category 1 of 9: Valves and Accessories	Added Star Manufacturer and Comment for Reclaimed Valve Boxes with lids
Section 650-B Approved Materials Checklist	Category 2 of 9 Service Materials	Updated ADS service tubing specification (CTS PE4710)

RECLAIMED

SUMMARY OF CHANGES

Chapter Six (6)	Section Name	Amendment Description
Section 650-B Approved Materials Checklist	Category 3 of 9: Pipe Materials	Updated JM Manufacturing name to JM-Eagle
Section 650-B Approved Materials Checklist	Category 4 of 9: Pipe Fittings	Updated Tyler Union Part Numbers and Comments for Restrained Joints, DIP, HDPE, and PVC
Section 650-B Approved Materials Checklist	Category 4 of 9: Pipe Fittings	Added Total Piping Solutions' Triple Tap Tapping Sleeves, DIP, PVC
Section 650-B Approved Materials Checklist	Categories 5-9 of 9 Plants and Remote Facilities	Added Approved Facility Equipment: Categories 5-9 (New), Manufacturers, Part Numbers, Comments
Section 650-F	Reclaimed System Schedule of Values - Page 4 of 4	Added Reviewer signature lines for Total Constructed Value \$ Amount at the end of this section

Authorization #7 - Amendments Effective August 4, 2016

Chapter Six (6)	Section Name	Amendment Description
Section 650-B Approved Materials Checklist	Category 4 of 9: Pipe Fittings	Added new vendor, SIP for fittings (C153 SSB/ C110 Flange, Restrained Joints (DIP, PVC)

Authorization #8 - Amendments Effective November 5, 2017

Chapter Six (6)	Section Name	Amendment Description
Section 611 Reclaim Water Facility SCADA Standards	All	Removed most in-depth SCADA and put in Chapter 7
Section 611 Reclaim Water Facility SCADA Standards	All	Updated what is stored in Historian. Agreed that all tags should be stored except in the case of using a bussed system which increases the number of tags exponentially
Section 611 Reclaim Water Facility SCADA Standards	All	Section 2.01/2.02 largely removed and put into Chapter 7
Section 611 Reclaim Water Facility SCADA Standards	All	Added unit process numbers similar to a water facility
Section 611 Reclaim Water Facility SCADA Standards	All	Added information that is monitored similar to other sections (water/wastewater)

RECLAIMED

SUMMARY OF CHANGES

Chapter Six (6)	Section Name	Amendment Description
Section 611 Reclaim Water Facility SCADA Standards	All	Reference Section 517 as panels are defined in that section previously (section 2.01)
Section 650-B Approved Materials Checklist	All	Edits, deletions and additions

Authorization #9 - Amendments Effective November 16, 2018

Chapter Six (6)	Section Name	Amendment Description
Section 610	Part 18 – Products, 18.02 Joint Materials	Remove fusible PVC direction drill application
Section 650 A Testing and Inspections for Acceptance	Part 3 – Execution, 3.01 Tests	Remove fusible PVC direction drill application
Section 650-B Approved Materials Checklist	Category 3 of 9 Pipe Material	Removed Fusible PVC (PVC 4-inch through 12-inch C-900, DR18, etc.); Added "and Fittings" to HDPE Pipe DR 11 and suppliers (ENDOT, WL Plastics); Added JCM 452 under Tapping Sleeves; excepted PVC-900 for Mueller Series Tapping Sleeves
Standard Drawings	RW-03: Reclaimed Water Master Meter Assembly (Larger than 2 inch)	Added protective bollards to assembly

Authorization #11 - Amendments Effective March 30, 2022

Chapter Four (4)	Section Name	Amendment Description
Section 650-B	Reclaimed Approved Materials Coversheet and Checklist, Category 1, 3, and 4 of 10	Revised cover sheet (shortened) related to instruction/use of materials; Update/Add vendors for valves/accessories, pipe, pipe fittings
Standard Drawings	WA-09-1 Master Meter Assembly (3" and larger) (Single Cross Connection Control Assembly)	Modify configuration
Standard Drawings	RW-03: Reclaimed Water Master Meter Assembly (Larger than 2 inch)	Modify configuration

RECLAIMED

SUMMARY OF CHANGES

Authorization #12 - Amendments Effective November 27, 2022

Chapter Six (6)	Section Name	Amendment Description
Section 610	Part 1 - General, Part 18.04 – Coatings and Linings for DIP and Fittings	Establish RGB color coding
Section 650-B Approved Materials Checklist	Preamble	Establish RGB color coding
Standard Drawings	RW-03: Reclaimed Water Master Meter Assembly (Larger than 2 inch)	Establish RGB color coding (Note 4)

CHAPTER 6

RECLAIMED WATER

Section 610

Reclaimed Water System Standards and Specifications

PART 1 - GENERAL

- A. The use of reclaimed water shall be governed by and in accordance with the most current edition of the "Utilities Reclaimed Water Policy Manual", the "Utilities Standards and Specifications Manual", the LAND DEVELOPMENT CODE, the COMPREHENSIVE PLAN, the Florida Plumbing Code, and "Chapter 62-610, Reuse of Reclaimed Water and Land Application, Part III, FAC".
- B. All reclaimed water pipes, piping, meter boxes, meter lids, meter dial faces, sprinkler heads, signage, and other related materials shall be appropriately identified and purple (RGB: 204, 153, 255) in color using light stable colorants.

PART 2 - NOT USED

PART 3 - MANDATORY CONNECTION

- A. Connection to a public access quality reclaimed water system shall be in accordance with the COMPREHENSIVE PLAN, the LAND DEVELOPMENT CODE, and the "Utilities Reclaimed Water Policy Manual".

PART 4 - LOCATION

- A. Refer to Chapter 4, "Potable Water System Standards and Specifications", Section 410, Part 2 - Location.

PART 5 - DESIGN BASIS

- A. Reclaimed water systems shall be designed to promote efficient reclaimed water usage. Reclaimed water mains shall be designed for the estimated ultimate irrigation demand, based on the planned build-out of the DEVELOPMENT. The DEVELOPER is responsible for sizing of the mains and related infrastructure, only for his DEVELOPMENT. Individual single-family homes are exempt from providing design calculations for irrigation systems with one inch or smaller meters.
- B. Average Daily Flows and Peak Flows for Single-Family Residential and Other Developments:
 - 1. Reclaimed water demand shall be calculated in accordance with the most restrictive criteria contained in the documents referenced in Part 1(A) above; and

CHAPTER 6

RECLAIMED WATER

Section 610

Reclaimed Water System Standards and Specifications

2. Irrigation zones shall be provided to uniformly distribute flows so that the maximum peak hourly factor is not exceeded. Alternate irrigation system designs will be evaluated on a case-by-case basis.

- C. Minimum Main Sizing for Single-Family Residential Developments:
 1. The peak hourly demand for reclaimed water mains shall be based on 50 percent of the lots irrigating simultaneously using a demand of 20 gpm per lot.

 2. Irrigation System Design Calculations:
 - a. DEVELOPER's ENGINEER shall submit signed, sealed, and dated design calculations with the final construction plans for all reclaimed water distribution projects. Calculations shall show that reclaimed water mains will have sufficient hydraulic capacity to transport peak hourly flows. All head losses and minor losses shall be included in calculations. Based on the calculations derived in the Sections above, the DEVELOPER's ENGINEER shall recommend a meter size for each irrigation zone as approved by PCU.

PART 6 - DESIGN

A. Pipe Cover:

A minimum cover of 36 inches shall be provided.

B. Pressure:

All reclaimed water mains shall be designed using a pressure of 35 psi. For master metered systems, the reclaimed water pressure shall be a minimum of 20 psi for each service connection.

C. Diameter:

Only 4, 6, 8, 10, 12, 16, 20, 24, 30, 36, 42, 48, and 54-inch diameter water mains shall be permitted. Variations in main size may be authorized by the COUNTY when deemed appropriate provided that the existing or proposed level of service is maintained and operational maintenance and responsibility is established to the benefit of the COUNTY. Looped systems shall be required in low-density residential developments. Where looping of mains is not practical, the diameter of dead end mains shall be increased by one pipe size as based on hydraulic modeling.

D. Velocity:

CHAPTER 6

RECLAIMED WATER

Section 610

Reclaimed Water System Standards and Specifications

Mains shall be sized so velocities do not exceed six feet per second under maximum daily flow conditions. In no case shall connections be made to cause velocities to exceed six feet per second in existing mains.

E. Design Friction Losses:

Friction losses through mains shall be based on the Hazen and Williams or Darcy-Wiesbach formulas. In the use of the Hazen and Williams formula, the value for "C" shall be 130 for all pipes.

F. Design Pressure and Restraint

1. The main and fittings, including all restrained joint pipe fittings shall be designed to withstand pump operating pressures and pressure surges, but not less than 150 psi.
2. The restrained joint lengths shall be calculated consistent with the table format shown in the STANDARD DRAWINGS.
3. In the event that it is necessary to locate proposed mains or leave existing mains longitudinally under any part of a proposed roadway subject to regular non-residential traffic or with speed limits above 30 miles per hour, such mains shall have restrained joints.

G. Dead Ends:

1. In order to provide increased reliability of service and reduce head loss, dead ends shall be minimized by making appropriate tie-ins whenever practical, as determined by PCU.

H. Valves:

Sufficient valves shall be provided on mains so that inconvenience and sanitary hazards will be minimized during repairs. Inline valves shall be located no more than 500 feet apart in commercial, industrial, and high-density residential areas and no more than 1000 feet in all other areas. In addition, inline valves shall be utilized to isolate a maximum of 40 ERC's in order to reduce inconveniences to other customers. A minimum of two valves per tee and three valves per cross shall be required to isolate and maintain adequate service. Valves shall be placed at phase lines and located at the end of all water main extensions except at cul-de-sacs. The County reserves the right to require additional isolation valves at tees, crosses, etc. as necessary for system operation.

I. Combination Air/Vacuum Release Valves:

CHAPTER 6

RECLAIMED WATER

Section 610

Reclaimed Water System Standards and Specifications

Automatic air release valves of appropriate size and number shall be installed in accordance with the STANDARD DRAWINGS to prevent air locking formation. Automatic combination air and vacuum release valves shall be utilized to prevent both air locking and vacuum formation. All such valves are required at significant high points of the main or as specified by PCU. Valves shall be clearly delineated on the profile view for each main in the PLANS. The ENGINEER shall submit calculations to PCU justifying the valve sizes and numbers as specified by AWWA M-51 "Air Release, Air/Vacuum, and Combination Air Valves".

J. Not Used

K. Booster Pumps:

Private in-line booster pumps are not permitted on RECLAIMED WATER SYSTEMS unless otherwise approved by POLK COUNTY.

L. Restrained Joints:

1. Pressure piping, fittings, and other items requiring restraint shall be restrained by assemblies or devices designed for the maximum pressure condition (test pressure) in accordance with the STANDARD DRAWINGS.
2. In the event that it is necessary to locate proposed mains or leave existing mains longitudinally under any part of a proposed roadway subject to regular non-residential traffic or with speed limits above 30 miles per hour, such mains shall have restrained joints or be constructed within steel casing(s).

M. Separation of Reclaimed Water Mains from Potable Water and Wastewater Systems:

Separation of reclaimed water, potable water, and wastewater system shall comply with FDEP regulations and PCU standards per the STANDARD DRAWINGS.

N. Materials:

1. Reclaimed water pipe shall be either PVC or ductile iron pipe.
2. HDPE may be used in specific applications as specified in this MANUAL or as approved by PCU. Using the PCU approved hydraulic modeling standards contained within this MANUAL, the ENGINEER shall determine on a case by case basis if it is necessary for all proposed

CHAPTER 6

RECLAIMED WATER

Section 610

Reclaimed Water System Standards and Specifications

HDPE pipe installations to be increased by one pipe size above all proposed or existing adjacent PVC and Ductile Iron Pipe installations.

- O. Signage and Public Notice:
 - 1. For all systems, there shall be readily identifiable "Reclaimed Water" or "Do Not Drink" notices, marking or coding on application/distribution facilities and appurtenances. Notification shall be accomplished by the posting of advisory signs designating the nature of the reclaimed project area where reclaimed is practiced, notes on scorecards or by other methods per the STANDARD DRAWINGS. Notification methods used include posting of advisory signs at entrances to residential neighborhoods, medians, right of ways, at the entrance to a golf course, and at the first and tenth tees. Advisory signs shall be posted adjacent to lakes or ponds used to store reclaimed water with a minimum of four signs or as determined by PCU. Advisory signs shall be posted at decorative water features that use reclaimed water and shall include the following text: "Do Not Drink" and "Do Not Swim" together per the STANDARD DRAWINGS.
 - 2. The DEVELOPER shall be responsible for all cost incurred and installation of reclaimed water signage in accordance with FDEP regulations and PCU standards. The OWNER responsible for operation and maintenance of the private irrigation system shall also be responsible for maintenance of the signage.
 - 3. PCU will be responsible for maintenance of signage for PCU RECLAIMED WATER SYSTEMS.

PART 7 - SYSTEM CONNECTION AND SERVICE CONNECTIONS

- A. Reclaimed water services and connections shall conform to the applicable provisions of this MANUAL. Only 1-inch services are permissible for reclaimed installations at residential locations. 2, 4, 6, 8, 10, and 12-inch services may be permitted for non-residential locations. PCU may install services and connections to existing reclaimed water systems up to two-inch, after payment of applicable fees and charges. The CONTRACTOR shall furnish service connections for new main extensions.

PART 8 - WATER METERING

- A. General:

CHAPTER 6

RECLAIMED WATER

Section 610

Reclaimed Water System Standards and Specifications

All reclaimed water service connections shall be metered. In general, the method of metering will follow the guidelines listed below and is subject to PCU's determination of appropriateness.

1. All meters shall be in accordance with Section 3 of the "Utilities Administration Manual" and the MANUAL's "Approved Meters List".
 2. An above ground meter assembly shall be required for all non-residential installations regardless of meter size.
 3. Single family and duplex residential meters that are two inches or smaller shall be installed in PCU approved meter boxes.
 4. On-site systems downstream of and served by a master meter assembly shall be maintained by the Homeowners Association, Owners Association, or the Property Owner unless otherwise determined and/or required by prevailing regulations or County requirements.
 5. The ENGINEER shall obtain approval before finalizing the metering system design.
 6. Unless specifically approved by PCU, meter boxes shall not be installed in sidewalks, driveways or areas subject to pedestrian or vehicular traffic.
 7. Meters subject to vehicular traffic shall be installed in a traffic rated meter box.
- B. Single Family, Duplex, and Town Homes Subdivisions with Public Rights of Way:
1. Each unit shall be individually metered. Meters shall be installed within the right-of-way in individual meter boxes as indicated in the STANDARD DRAWINGS
 2. Town Homes Subdivisions shall install a master meter for individual buildings or groups of buildings.
 3. On-site reclaimed water systems downstream of and served by a master meter assembly shall be maintained by the Homeowners Association, Owners Association, or Property Owner.
- C. Single Family and Town Homes Subdivisions with Private Rights-of- Way:

CHAPTER 6

RECLAIMED WATER

Section 610

Reclaimed Water System Standards and Specifications

1. If easements are dedicated over the entire private street common areas, individual meters may be permitted in accordance with PART 8 (B). Additionally, private streets shall meet COUNTY standards and sufficient area must be available outside of paved areas to locate water mains, services, and meters. If these criteria cannot be met, the subdivision shall be metered pursuant to PART 8, (D).
 2. Town Homes Subdivisions shall install a master meter for individual buildings or groups of buildings.
 3. On-site reclaimed water systems downstream of and served by a master meter assembly shall be maintained by the Homeowners Association, Owners Association, or Property Owner.
- D. Commercial, Industrial, Institutional, Shopping Centers, Apartments, and Condominium Projects:

In general, all such projects shall require installation of a master meter assembly to service the entire development. In general, shopping centers and associated out parcels shall require installation of a single meter to service the entire development unless out parcels are adjacent to public right of way or otherwise approved by PCU.

- E. Meter Installation:
1. Meters that are larger than two inches shall be installed by the DEVELOPER.
 2. Installation of meters that are two inches and smaller will be performed by PCU.
 3. Single family residential meters that are one inch and smaller in size shall be installed underground in an approved meter box.
 4. All other meters shall be installed above ground and located in a Polk County Utilities Easement located adjacent to but outside of the public right of way per the STANDARD DRAWINGS.
 5. Where meters are to be installed by PCU in an above ground assembly, the DEVELOPER shall install an appropriately sized lockable curb stop and meter box (if applicable) in the location designated for the meter in order to facilitate ease of installation of the meter by PCU.
- F. Meter Sizing:
-

CHAPTER 6

RECLAIMED WATER

Section 610

Reclaimed Water System Standards and Specifications

PCU shall approve the size and quantity of all meters. The ENGINEER shall recommend meter sizes and provide sufficient information on estimated average daily and peak flows to justify each meter size.

PART 9 - MATERIALS, INSTALLATION, AND TESTING

- A. Applicable provisions of the MANUAL shall apply.

PART 10 - LOCATION AND IDENTIFICATION

- A. A means for locating and identifying all reclaimed water mains and valves shall be provided in accordance with the MANUAL and the STANDARD DRAWINGS.

PART 11 - IRRIGATION WELLS

- A. General:

Private wells shall not be connected to any portion of the PCU RECLAIMED WATER SYSTEM, either directed or indirectly, without the installation of an approved cross connection control assembly on the customer's side of the reclaimed water meter.

- B. Ground Water Protection:

Existing or proposed wells utilized for back-up supply of irrigation water to a private irrigation system shall be protected from reclaimed and non-potable water entering the well by either an air-gap or an approved cross connection control assembly.

PART 12 - ON-SITE STORAGE

- A. The installation of an on-site storage facility with a backup irrigation well may be utilized with the approval of PCU. Said storage facility shall be separated from the reclaimed water system by an air-gap or an approved cross connection control assembly. The volume of the on-site storage ponds or tanks shall be equal to or greater than the annual average daily demand during a 24-hour period.
- B. Single-family residential developments, where PCU will own, operate, and maintain the on-site distribution system are exempt from on-site storage requirements.

CHAPTER 6

RECLAIMED WATER

Section 610

Reclaimed Water System Standards and Specifications

PART 13 - APPROVED USES OF RECLAIMED WATER

- A. In addition to citrus groves, landscaping, and golf courses, other uses of reclaimed and non-potable water may be acceptable if the following requirements are met:
 - 1. Specific approval by PCU.
 - 2. All requirements of "Chapter 62-610, Reuse of Reclaimed Water and Land Application, Part III, FAC" are met.
- B. Other Approved Uses of Reclaimed Water:
 - 1. Construction dust control;
 - 2. Outdoor aesthetic feature including fountains, ponds, and lagoons;
 - 3. Cleaning roads, sidewalks and other outdoor work areas;
 - 4. Industrial process water; and
 - 5. Cooling towers.

PART 14 - PROHIBITED USES OF RECLAIMED WATER

- A. The following uses of reclaimed water are prohibited:
 - 1. Fire protection - the use of reclaimed water as a primary supply source for fire hydrants and fire sprinkler systems;
 - 2. Toilet flushing - reclaimed water shall not be connected to any internal building plumbing fixture or piping utilized for toilet flushing or other potable water systems;
 - 3. Laundry water supply;
 - 4. Swimming pools or spas;
 - 5. Single family residential air conditioning systems;
 - 6. Vehicle washing, unless otherwise approved by FDEP for commercial car wash facilities;
 - 7. Manufacture of ice for ice rinks; and
 - 8. Hose bibs.

CHAPTER 6

RECLAIMED WATER

Section 610

Reclaimed Water System Standards and Specifications

PART 15 - CROSS CONNECTION CONTROL

A. General:

Cross connection control requirements shall be as specified in the "Cross Connection Control Policy Manual".

PART 16 - PROTECTION OF RECLAIMED WATER SYSTEM

A. General:

1. DEVELOPMENTS that use reclaimed water with chemical injection and/or storm water augmentation systems that add potential contaminants such as fertilizer, pesticides, algaecides, etc., shall as a minimum, require installation of an approved double check valve cross connection control assembly. Projects with a higher degree of hazard, such as saline solutions, etc., may be required to install an approved reduced pressure principle cross connection control assembly.

B. Location and Installation:

All cross connection control assemblies required under the above conditions shall be installed and maintained in accordance with the "Cross Connection Control Policy Manual".

PART 17 - CONSTRUCTION

17.01 SCOPE OF WORK

- A. These specifications cover the pipes, fittings, and appurtenances used for reclaimed water distribution systems.
- B. The CONTRACTOR shall replace, at his expense, all materials found to be defective or damaged in handling or storage. The CONTRACTOR shall, if requested by PCU, furnish certificates, affidavits of compliance, test reports, or samples for analysis for any of the materials specified herein. All pipe delivered to project site for installation is subject to random testing for compliance with the designated specifications.
- C. Pipe and fitting interior linings shall conform to ANSI/NSF 61 list of approved materials standard.
- D. Reclaimed water mains, water service piping, and connections shall be installed as indicated in the STANDARD DRAWINGS.

CHAPTER 6

RECLAIMED WATER

Section 610

Reclaimed Water System Standards and Specifications

- E. Fire hydrant assemblies shall not be installed on any part of a reclaimed water system.

PART 18 - PRODUCTS

18.01 PIPE MATERIALS

- A. PVC Pipe:

PVC reclaimed water distribution mains shall be manufactured in accordance with AWWA standard C900, C905, or C909, latest edition. Pipe that is 4 to 12 inches in diameter shall be C900 and have a dimension ratio of 18. Pipe larger than 12 inches in diameter shall be C905 or C909 and have a dimension ratio of 25. Pipe shall be pantone purple 522c in color.

- B. Ductile Iron Pipe:

Ductile iron pipe shall conform to ANSI/AWWA A21.51/C151. Pipe shall be pressure class 350 for 3-inch to 12-inch, pressure class 250 for 16-inch to 20-inch, pressure class 200 for 24-inch, and pressure class 150 for 30-inch to 64-inch.

- C. HDPE Pipe:

HDPE pipe shall be in accordance with AWWA C906 and shall have an outside diameter equal to ductile iron pipe for the same size. Pipe shall have a minimum dimension ratio of 11 for use with ductile iron pipe fittings and have a working pressure of 150 psi. Pipe shall have integral pantone purple 522c in color identification stripping. All HDPE pipe and tubing shall be at least one pipe size larger than adjacent PVC and Ductile Iron Pipe.

18.02 JOINT MATERIALS

- A. PVC Pipe Joints:

PVC pipe shall have integral bell push on type joints conforming to ASTM D3139.

- B. Ductile Iron Pipe Joints:

Joints for ductile iron pipe shall be push-on or mechanical joints conforming to ANSI/AWWA A21.11/C111., Restrained or flanged joints shall be provided where called for in the PLANS. Flanged points shall conform to AWWA C115.

- C. HDPE Pipe Joints:

CHAPTER 6

RECLAIMED WATER

Section 610

Reclaimed Water System Standards and Specifications

HDPE joints shall conform to AWWA C906.

18.03 FITTINGS

A. Ductile Iron and PVC Pipe:

Fittings shall be mechanical joint ductile iron compact fittings in accordance with ANSI/AWWA A21.53/C153.

B. HDPE Pipe:

1. Fittings used with HDPE pipe shall be mechanical joint ductile iron compact fittings in accordance with ANSI/AWWA A21.53/C153 unless otherwise specifically approved by PCU.

18.04 COATINGS AND LININGS FOR DUCTILE IRON PIPE AND FITTINGS

A. Ductile iron pipe and fittings shall have an interior protective lining of cement-mortar with a seal coat of asphaltic material in accordance with ANSI/AWWA A21.4/C104. Exterior ductile iron pipe shall be coated with asphaltic material in accordance with a minimum one mil thick in accordance with ANSI/AWWA A21.51/C151.

B. Additional Applied Exterior Coatings for Above Ground Pipe and Fittings. Pipe, fittings, and valves shall be thoroughly cleaned and given one field coat (minimum 1.5 mils dry thickness) of rust inhibitor primer in addition to the factory applied coat of rust inhibitor primer. Intermediate and finished field coats of Alkyd shall also be applied by the CONTRACTOR to a minimum 1.5 mil dry thickness for each coat. Primer and field coats as specified in the appropriate "Approved Materials Checklist" shall be compatible and be applied in accordance with the manufacturer's recommendations. The final field coat shall be purple (RGB: 204, 153, 255) for finished reclaimed water.

18.05 POLYETHYLENE ENCASEMENT

A. Polyethylene encasement shall be in accordance with ANSI/AWWA A21.51/C105 with wrapping colors to be Pantone 522c purple. Polyethylene encasements are required in accordance with C105 and when crossing, or adjacent to, power easements and gas easements.

18.06 SERVICE PIPE, STOPS, FITTINGS, AND SERVICE SADDLES

A. Service Connections at Main:

CHAPTER 6

RECLAIMED WATER

Section 610

Reclaimed Water System Standards and Specifications

1. Service connections of one and two-inches shall be brass body reduced port type corporation stops, equipped with connections compatible with the polyethylene tubing and threaded in accordance with specifications in AWWA C800, AWWA C901, and shall comply with NSF-61. One and two-inch services at the water main shall have connections for female iron pipe by female iron pipe thread, conforming to AWWA C509.
 2. Service connections, 4-inch through 12-inch, shall have iron body resilient seat gate valves.
 3. Service taps for air release valve installations shall utilize a 2-inch brass ball type corporation stop.
- B. Service Pipe:
1. One-inch and two-inch service lines shall be Pantone 522c purple polyethylene tubing, conforming to specifications in AWWA C800, SDR 9, and AWWA C901.
 2. Service lines, that are 4, 6, 8, 10, and 12 inches in size, shall be as water main pipe.
- C. Service Control Valves at Property Line:
1. One-inch and two-inch size service control valves shall be reduced port ball valves, made of brass, cast and machined in accordance with specifications in AWWA C800, AWWA C901, compliant with NSF-61 and compatible polyethylene tubing connections.
 2. For connections larger than two-inches, the CONTRACTOR shall provide resilient seat gate valves.
- D. Service Fittings:
1. One-inch and two-inch fittings shall be brass, cast and machined in accordance with specifications in AWWA C800 and AWWA C901, and shall comply with NSF-61 with compatible polyethylene tubing connections.
 2. Fittings, that are 4, 6, 8, 10, and 12 inches in size, shall be the same as reclaimed water main fittings.
- E. Service Tapping Saddles:

CHAPTER 6

RECLAIMED WATER

Section 610

Reclaimed Water System Standards and Specifications

1. Stainless Steel Service Saddles:
2. Epoxy or nylon coated stainless steel, 18-8 type 304 straps, AWWA tapered threads, two inches to be iron pipe threads. Controlled OD saddles to be used on C900 and IPS OD PVC pipe, double straps to be 2-inch minimum width each, single strap to be minimum of three inches wide.
3. Service Connections:
 - a. PVC and HDPE Pipe Service Saddle:
 - i. One-inch and two-inch services utilize brass body saddle with controlled OD.
 - ii. Four-inch or larger services shall be mechanical tapping sleeves, stainless steel sleeve for size on size taps, or epoxy coated sleeve with stainless steel hardware for all other sizes.
 - b. Ductile Iron Pipe Service Saddle:
 - iii. One-inch and two-inch services shall use a controlled OD service tapping saddle with stainless steel straps and a ductile iron body that is either nylon or epoxy coated.
 - iv. Four-inch or larger services shall be mechanical tapping sleeves, stainless steel sleeve for size on size taps, or epoxy coated sleeve with stainless steel hardware for all other sizes.

18.07 RESILIENT SEAT GATE VALVES

- A. Gate valves shall be resilient seat gate valves, manufactured to meet or exceed the requirements of AWWA C515, latest revision, and in accordance with these SPECIFICATIONS. Valves shall have an unobstructed waterway equal to or greater than the full nominal diameter of the valve. Valves shall have a minimum pressure rating of 150 psi.
- B. Valves that are 16 inches and larger shall have side actuators. The valve body, bonnet, and bonnet cover shall be ductile iron ASTM A126, Class B. All ferrous surfaces inside and outside shall have a fusion-bonded epoxy coating in accordance with AWWA C 550. A two-inch wrench nut shall be provided for operating the valve. All valves are to be tested in strict accordance with AWWA C515.
- C. Directional Opening:

All valves shall open left or counter clockwise.

CHAPTER 6

RECLAIMED WATER

Section 610

Reclaimed Water System Standards and Specifications

- D. The valves shall be non-rising stems with the stem made of cast, forged, or rolled bronze as specified in AWWA C515. Two stem seals shall be provided and shall be of the O-ring type. The stem nut must be independent of the gate.
- E. The resilient sealing mechanism shall provide zero leakage at test and normal working pressure when installed with the line flow from either direction.

18.08 BUTTERFLY VALVES

- A. Typically, butterfly valves shall not be installed within any PCU system, except directly adjacent to storage tanks for isolation purposes or as specifically approved by PCU for control meter assemblies.
- B. Butterfly valves and operators shall conform to the "AWWA Standard Specifications for Rubber Seated Butterfly Valves", Designation C504, latest version, except as hereinafter specified, shall be Class 150A or B.
- C. The valve body materials shall be epoxy coated inside and out as per AWWA C550. The valve body shall be constructed of close grain cast iron per ASTM A126, Class B or equivalent material. All retaining segments and adjusting devices shall be of corrosion resistant material.
- D. Valve seats shall be a natural rubber or synthetic rubber compound. Valve seats shall be field adjustable and replaceable without dismounting operator disc or shaft and without removing the valve from the line. All retaining segments and adjusting devices shall be of corrosion resistant material.
- E. The face-to-face dimensions of valves shall be in accordance with above-mentioned AWWA specification for short-body valve.
- F. Should PCU find it necessary to install butterfly valves along mains that are 16 inches in diameter or larger, a 6-inch minimum bypass with one gate valve shall be installed around each valve.
- G. The valve shaft shall be turned, ground, and polished constructed of 18-8 stainless steel and designed for both torsional and shearing stresses when the valve is operated under its greatest dynamic or seating torque. Shaft shall be of either a one-piece unit extending full size through the value disc and valve bearing or it may be of a stub shaft design.
- H. Valve Actuator:

CHAPTER 6

RECLAIMED WATER

Section 610

Reclaimed Water System Standards and Specifications

In general, the butterfly valve actuators shall conform to the requirements of AWWA standard specifications for "Rubber Seated Butterfly Valves, Designation C504", insofar as applicable.

I. Directional opening:

All valves shall open left or counter clockwise.

18.09 VALVE BOXES

A. Standard Three-Piece Cast Iron Valve Box:

Three-piece valve boxes are required for mains less than six feet below finished grade as indicated in the STANDARD DRAWINGS. Valve boxes shall meet AWWA standards and be provided with suitable heavy duty ductile or cast iron bonnets and shall extend to such elevation at or slightly above the finished grade surface as directed by PCU. The barrel shall be screw type only and have a 5-1/4-inch shaft. The upper section shall have a flange at the bottom having sufficient bearing area to prevent settling and shall be complete with cast iron covers. Ductile or cast iron covers shall have "RECLAIMED" cast into the top for all water mains.

B. Valve Box Assembly:

Valve box assemblies, as indicated in the STANDARD DRAWINGS, are required for any size main whenever the top of the valve nut is six feet or deeper below the finished surface elevation that is directly above the valve location. Valve boxes shall be one complete assembled unit composed of the ductile or cast iron valve box with a 5-1/4 inch barrel shaft and steel extension stem that attaches to the valve body. All moving parts of the extension stem shall be enclosed in a housing to prevent contact with the soil. Valve box assembly shall be adjustable to accommodate variable depths.

C. The stem assembly shall be of a telescoping design that allows for variable adjustment length. The material shall be galvanized square steel tubing. The stem assembly shall have a built-in device that prevents the stem assembly from disengaging at its fully extended length. The extension stem must be capable of surviving a torque test to 1,000 ft-lb without failure.

D. Valve boxes, located in roadways with speed limits above 30 miles per hour or on mains that are 16 inches in diameter or larger, shall have locking lids

CHAPTER 6

RECLAIMED WATER

Section 610

Reclaimed Water System Standards and Specifications

utilizing a five sided nut with a special wrench needed to open. Valve lids to be made as shown in the STANDARD DRAWINGS.

- E. A test station box shall be installed into the valve pad for the placement of the locating wire as shown in the STANDARD DRAWINGS. The test station box shall be as specified in the appropriate "Approved Materials Checklist".
- F. Locating wire shall be 14-gauge single strand solid core copper wire with insulation. The color of the insulation shall be the same color as the color code for the pipe being installed.
- G. Each valve marker shall be made of bronze with each specific valve's information clearly imprinted on its top surface, provided with a hanger pin, and installed in each valve collar as shown in the STANDARD DRAWINGS.

18.10 AIR RELEASE VALVES

- A. Valves for use in reclaimed water mains shall be single body type valves designed to release large quantities of air at start up, admit air on shut down and release air in operation. Automatic combination air and vacuum release valves shall be utilized to prevent both air locking and vacuum formation. Valves shall be made of either high strength plastic with corrosion resistant polymer materials or have a cast iron body, cover and baffle, stainless steel float, bronze water diffuser Buna-N or Viton seat and stainless steel trim. Valves must be installed in an above ground enclosure as shown on the STANDARD DRAWINGS. Fittings from the main to the air release valve in the enclosure shall be threaded and made of brass.

PART 19 - CONSTRUCTION

19.01 MATERIAL IDENTIFICATION AND TESTING

- A. Pipe Identification and Location:
 - 1. Each length of pipe shall bear the name or trademark of the manufacturer, the location of the manufacturing plant, and the class or strength classification of the pipe. The markings shall be plainly visible on the pipe barrel. Pipe, which is not clearly marked, is subject to rejection. The CONTRACTOR shall remove all rejected pipe from the project site within five working days.
 - 2. All PVC pipe and other pipe that is factory color-coded on the outside surface of the pipe shall be identified and locatable as specified in the STANDARD DRAWINGS. All D I pipe, and other pipe not factory color-

CHAPTER 6

RECLAIMED WATER

Section 610

Reclaimed Water System Standards and Specifications

coded on the outside surface, shall be identified as specified in the STANDARD DRAWINGS. DI pipe shall meet all applicable requirements of AWWA C151. Where the above type of identification method is not considered to be practical by PCU, the pipe shall have a field applied three inch wide permanent Pantone 522c purple paint stripe down the top outside center of the pipe along its entire length.

- B. Material Testing Requirements:
1. If requested by PCU, a sample of pipe to be tested shall be selected at random by PCU or the testing laboratory hired by PCU.
 2. When the samples tested conform to applicable standards, all pipe represented by such samples shall be considered acceptable based on the test parameters measured. Copies of test reports shall be available before the pipe is installed on the project.
 3. In the event that any of the test samples fail to meet the applicable standards, all pipe represented by such tests shall be subjected to rejection. The CONTRACTOR may furnish two additional test samples from the same shipment or delivery, for each sample that failed and the pipe will be considered acceptable if all of these additional samples meet the requirements of the applicable standards. All such retesting shall be at the CONTRACTOR's expense.
 4. Pipe, which has been rejected by PCU, shall be removed from the site of the work by the CONTRACTOR and replaced with pipe that meets these specifications.

19.02 SEPARATION OF MAINS

- A. Separation shall be in accordance with the STANDARD DRAWINGS.

19.03 INSTALLATION OF VALVES

- A. All valves shall be inspected upon delivery in the field to insure proper working order before installation. They shall be set and jointed to the pipe in the manner as set forth in the AWWA Standards for the type of connection ends furnished. All valves and appurtenances shall be installed true to alignment and rigidly supported. Any damage to the above items shall be repaired to the satisfaction of PCU before they are installed.

CHAPTER 6

RECLAIMED WATER

Section 610

Reclaimed Water System Standards and Specifications

19.04 NOTIFICATION OF CONNECTION TO EXISTING MAINS

- A. PCU shall be notified at least five NORMAL WORKING DAYS in advance to schedule main connections and valve operations. All existing valves are to be operated only by PCU. All valves installed are to remain closed during construction.

The CONTRACTOR shall exercise extreme caution when excavating in proximity of PCU mains. PCU main locations shown on plans are not exact or guaranteed. The CONTRACTOR is responsible for field verifying existing utility locations. PCU dispatch operator shall be notified immediately in the event of a force main, water main, or reclaimed water main break or damage. The CONTRACTOR shall immediately repair all damage to PCU mains, at the CONTRACTOR's expense. If the repair is not made in a timely manner, as determined by the PCU Inspector, PCU may perform repairs and the CONTRACTOR will be charged for repairs.

19.05 RECLAIMED WATER SERVICE LOCATION AND IDENTIFICATION

- A. The location of all service lines shall be as shown on the STANDARD DRAWINGS. On curbed streets, the exact location of each service shall be adequately and permanently identified using durable plastic purple (pantone 522c) colored pavement markers that states "Reclaimed Water Service" and "Call Before You Dig" as specified by the appropriate "Approved Materials Checklist". Each marker shall be securely attached to the curb in accordance with the manufacturer's guidelines approximately 6 inches from the top of the curb.
- B. Where no curb exists, the exact location of each service shall be adequately and permanently identified using durable plastic purple (pantone 522c) colored pavement markers that states "Reclaimed Water Service" and "Call Before You Dig" as specified by the appropriate "Approved Materials Checklist". Each marker shall be securely attached to the pavement in accordance with the manufacturer's guidelines approximately 6 inches from the edge of pavement.

19.06 RECLAIMED WATER VALVE LOCATION AND IDENTIFICATION

- A. The location of all service lines shall be as shown on the STANDARD DRAWINGS. On curbed streets, the exact location of each service shall be adequately and permanently identified using durable plastic purple (pantone 522c) colored pavement markers that states "Reclaimed Water Valve" and "Call Before You Dig" as specified by the appropriate "Approved Materials Checklist". Each marker shall be securely attached to the curb in accordance

CHAPTER 6

RECLAIMED WATER

Section 610

Reclaimed Water System Standards and Specifications

with the manufacturer's guidelines approximately 6 inches from the top of the curb.

- B. Where no curb exists, the exact location of each service shall be adequately and permanently identified using durable plastic purple (pantone 522c) colored pavement markers that states "Reclaimed Water Valve" and "Call Before You Dig" as specified by the appropriate "Approved Materials Checklist". Each marker shall be securely attached to the pavement in accordance with the manufacturer's guidelines approximately 6 inches from the edge of pavement.

Reclaimed Water SCADA Specifications

PART 1 - GENERAL RECLAIMED WATER SCADA STANDARDS

1.01 SUMMARY OF SYSTEM

- A. These standards represent minimum requirements for County projects at the time the standards were adopted. The County reserves the right to approve changes based on site specific design requirements. Refer to Chapter 7 of the Utility Code for additional information relating to SCADA standards applying to all County Water, Wastewater, and Reuse Facilities.
- B. Reclaimed water storage and pumping facilities shall be able to be monitored and controlled remotely. The CONTRACTOR shall provide a Remote Terminal Unit (RTU) and integration with Supervisory Control and Data Acquisition as identified in this Section. Additional reference for remote control panels is included in Section 517.
- C. The SCADA process data shall be organized as identified below:

<u>Unit Process Number¹</u>	<u>Process Name</u>
10	Inlet Flow
20	NOT USED
30	NOT USED
40	Reclaimed Storage
50	High Service Repumping With Flow Rate
60	Filtration (Not Typically Used)
70	Pressure Control
80	Chemical Storage and Feed
90	Electrical Power

- D. SCADA tag numbering shall be in accordance with Chapter 7 of the Utility Code.

1.02 RECLAIMED EQUIPMENT TO BE MONITORED AND CONTROLLED

- A. The following typical elements at standard unit processes must be monitored and controlled at the various unit processes with alarms as defined:

¹ For process numbers not identified above, an approved Unit Process Number shall be obtained from the County.

Reclaimed Water SCADA Specifications

1. UP 10 Influent Flow Meter

Monitored Data

- a. Instantaneous Flow
- b. Totalized Daily Flow, Current and Previous Day
- c. Daily Max/Min/Average.

Alarms

- a. Out of Range (High and Low Flow).
- b. Transmitter Fail/Loss of signal (outside 4-20mA range in accordance with manufacturer's fail output levels).

2. UP 40 Ground Storage

a. Levels/Valves

Monitored Data

- i. Ground Storage Tank Levels
- ii. Calculated Ground Storage Tank Volumes
- iii. Calculated Rate of Change (gpm) in Storage

Alarms

- i. High Ground Storage Level
- ii. Low Ground Storage Level
- iii. Valve Failure

3. UP 50 Reclaimed High Service Pumping

a. Pumps

Monitored Data

- i. Pump Motor Status
- ii. VFD Speed
- iii. Pressure
- iv. Flow Rate

Alarms

- i. Pump Over-Torque
- ii. Pump Fail

Reclaimed Water SCADA Specifications

- iii. Flow Out of Range
- iv. High Pressure
- v. Low Pressure

4. UP 80 Chemical Storage and Feed

a. Chemical Feed and Monitoring

Monitored Data

- i. Sodium Hypochlorite Level/Volume
- ii. Sodium Hypochlorite Pump Status
- iii. Sodium Hypochlorite Pump Stroke
- iv. Sodium Hypochlorite Pump Speed
- v. Eye Wash Status

Alarms

- i. Sodium Hypochlorite Pump Failure
- ii. Exhaust Fan Failure
- iii. Eyewash In Use or Failure
- iv. High Sodium Hypochlorite Level
- v. Low Sodium Hypochlorite Level

5. UP 90 Electrical Power

a. Electrical Line Power

Monitored Data

- i. Phase Voltage Difference from pump control panel phase monitor where applicable.
- ii. Phase-to-Phase Voltage.
- iii. Phase-to-Neutral Voltage where applicable.
- iv. Phase Current
- v. Real Power kW
- vi. Volt-Amps
- vii. Watt-Hours
- viii. Power Factor
- ix. Frequency
- x. Percent THD
- xi. Tie-Breaker Status where applicable
- xii. Main Breaker Status where applicable

Reclaimed Water SCADA Specifications

- xiii. Generator Breaker status where applicable
- xiv. UPS Status
- xv. 24 Volt DC Failure
- xvi. 120 Volt AC Failure

Alarms

- i. Low Voltage
- ii. High Voltage
- iii. Loss of Power
- iv. Phase Unbalance.

b. Generator Power

Monitored Data

- i. Generator Status
- ii. Phase-to-Phase Voltage
- iii. Phase Current
- iv. Fuel Level
- v. Transfer Switch Status

Alarms

- i. Low Voltage
- ii. High Voltage
- iii. Generator Failure
- iv. Transfer Switch Failure
- v. Fuel Leak
- vi. Low Fuel

1.03 DATA TO BE STORED IN HISTORIAN

- A. All tag data shall be stored in the Historian for facilities that do not use digital or bus-type networks. The following typical data are minimum requirements that shall be stored for bussed systems, and shall include alarm at unit processes. Historical data shall be stored at a minimum rate of one point every ten seconds, or a change greater than a set dead-band, and shall be stored as defined:

1. UP 10 Influent Flow Meter

Monitored Data

Reclaimed Water SCADA Specifications

- a. Instantaneous Flow
 - b. Totalized Daily Flow, Current and Previous Day
 - c. Daily Max/Min/Average.
2. UP 40 Ground Storage
 - a. Levels/Valves

Monitored Data
 - i. Ground Storage Tank Levels
 - ii. Calculated Ground Storage Tank Volumes
Alarms
 - i. Valve Failure
3. UP 50 Reclaimed High Service Pumping
 - a. Pumps

Monitored Data
 - i. Pump Motor Status
 - ii. VFD Speed
 - iii. Pressure
 - iv. Flow Rate
 - v. Flow Verification (CheckValve Closed Status or Flow Switch)
Alarms
 - i. Pump Fail
 - ii. Flow Meter Failure
4. UP 80 Chemical Storage and Feed
 - a. Chemical Feed and Monitoring

Monitored Data
 - i. Sodium Hypochlorite Level/Volume
 - ii. Sodium Hypochlorite Pump Status
 - iii. Sodium Hypochlorite Pump Stroke
 - iv. Sodium Hypochlorite Pump Speed
 - v. Eye Wash Status

Reclaimed Water SCADA Specifications

Alarms

- i. Sodium Hypochlorite Pump Failure
- ii. Eyewash In Use or Failure

5. UP 90 Electrical Power

a. Electrical Line Power

Monitored Data

- i. Phase-to-Phase Voltage
- ii. Phase-to-Neutral Voltage where applicable
- iii. Phase Current
- iv. Real Power kW
- v. Volt-Amps
- vi. Watt-Hours
- vii. Power Factor
- viii. Frequency
- ix. Percent THD
- x. Tie-Breaker Status where applicable.
- xi. Main Breaker Status where applicable.
- xii. UPS Status
- xiii. 24 Volt DC Failure
- xiv. 120 Volt AC Failure

Alarms

- i. Loss of Power
- ii. UPS Failure
- iii. 24 Volt DC Failure
- iv. Low Voltage
- v. High Voltage
- vi. Phase Unbalance

b. Generator Power

Monitored Data

- i. Generator Status
- ii. Phase Voltage Difference
- iii. Phase Amperage
- iv. Fuel Level
- v. Transfer Switch Status

Reclaimed Water SCADA Specifications

Alarms

- i. Generator Failure
- ii. Low Voltage
- iii. High Voltage
- iv. Transfer Switch Failure
- v. Low Fuel Level

PART 2 - COMPONENTS AND INTEGRATION

2.01 SOFTWARE, RTU, and NETWORK COMPONENTS

- A. Refer to Section 517 and Chapter 7 of the Utility Code for specific requirements.

2.02 INSTRUMENTATION

- A. Refer to Chapter 7 of the Utility Code for specific requirements.

2.03 STANDARD SCREENS

- A. The following pages are intended to be standard screens as a basis for creating reclaimed water remote site SCADA pages. The screens shall be used as a basis by both designers and integrators.

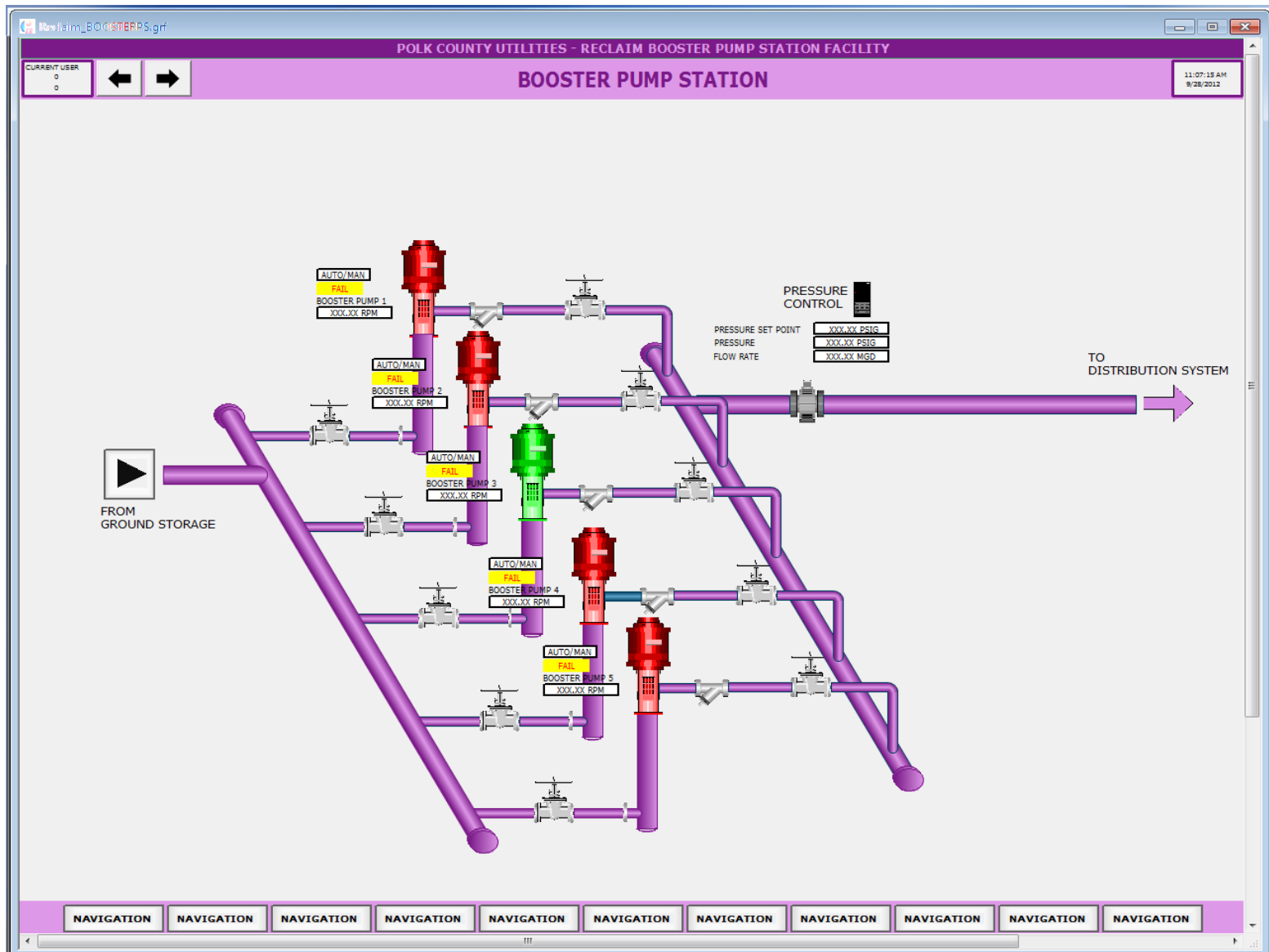

RWS-01

CHAPTER 6

RECLAIMED WATER

Section 611

Reclaimed Water SCADA Specifications

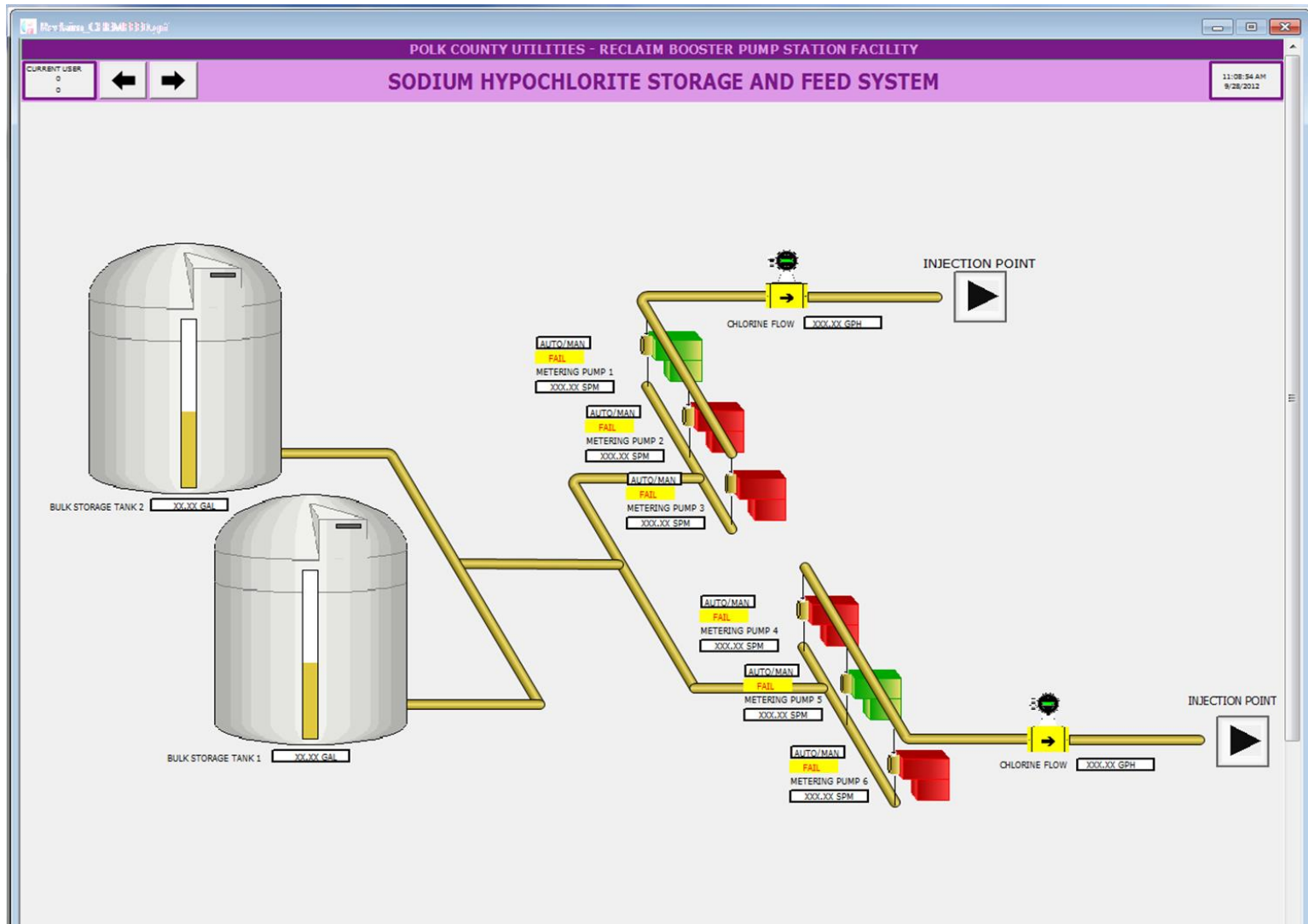

RWS-02

Reclaimed Water SCADA Specifications

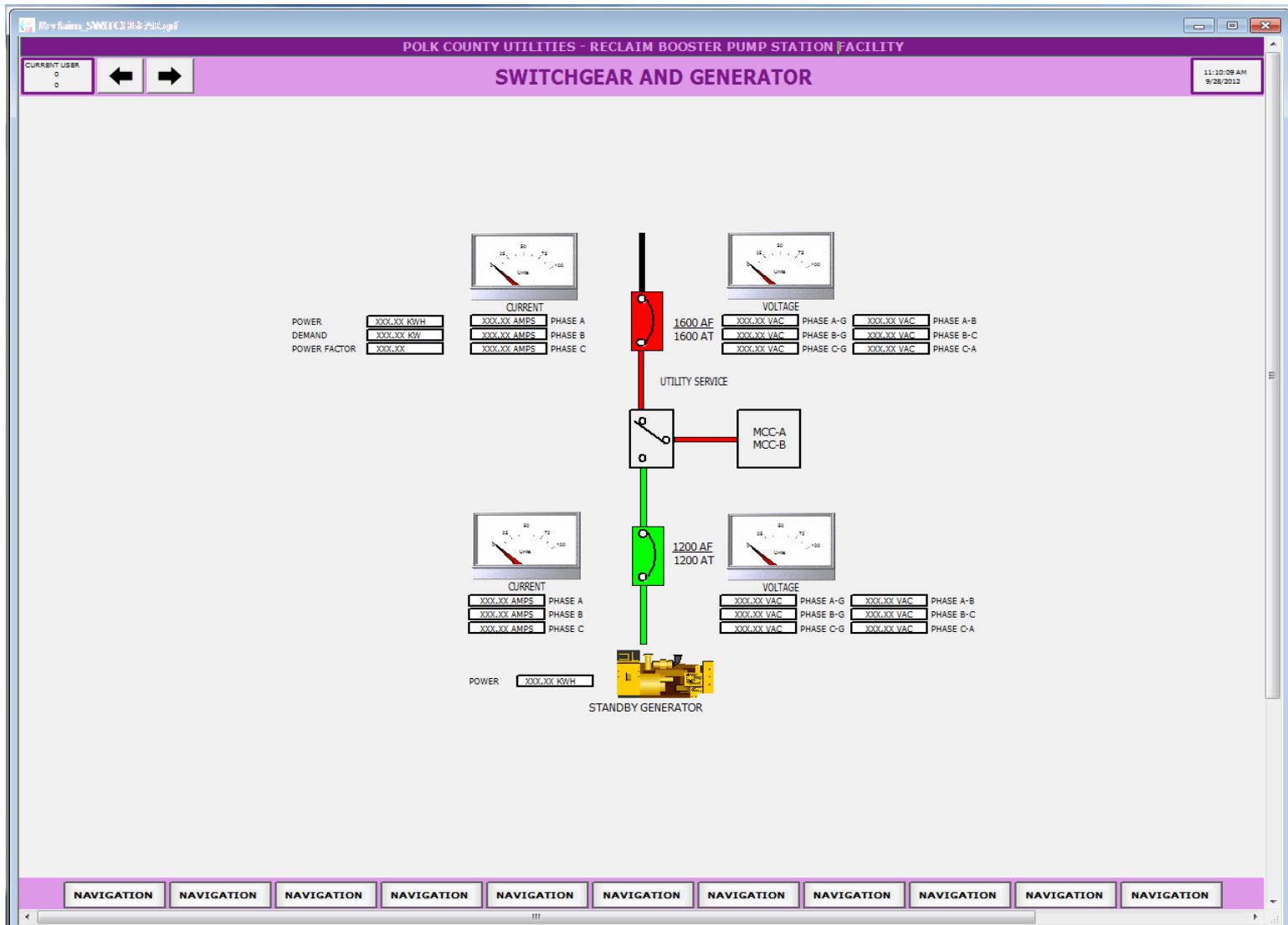

RWS-03

CHAPTER 6

RECLAIMED WATER

Section 650

STANDARD DRAWINGS

RW-01	Reclaimed Water Signage (“Do Not Drink Water”)
RW-02	Reclaimed Water Signage (“Do Not Drink / Do Not Swim”)
RW-03	Reclaimed Water Master Meter Assembly

CHAPTER 6

RECLAIMED WATER

Section 650-A

Testing and Inspection for Acceptance

PART 1 - GENERAL

1.01 SCOPE OF WORK

- A. These specifications cover the testing and inspection for the acceptance of reclaimed water systems.
- B. Hydrostatic tests shall be conducted for pressure pipes, joints, fittings and valves for allowable limits of pressure and leakage. Air testing of pressure pipes will not be permitted under any circumstance.
- C. Requests for testing and acceptance of reclaimed water systems shall follow the procedure in listed in the Section entitled "Field Testing and Inspection Procedures".
- D. The purpose of swabbing a new pipeline is to conserve water while thoroughly cleaning the pipeline of all foreign material, sand, grit, gravel, construction debris and other items not found in a properly cleaned system. Prior to pressure testing of a new pipeline, swabbing shall be utilized as specified on the construction plans for each project.

PART 2 - PRODUCTS (NOT USED)

PART 3 - EXECUTION

3.01 TESTS

- A. Pipe cleaning shall be accomplished through a full diameter preliminary flush followed by swabbing (also known as pigging).
 - 1. The preliminary flush shall have a minimum velocity of 0.5 feet per second velocity throughout the main's full diameter in accordance with AWWA C651.
 - 2. Swabbing
 - a. All mains shall be hydraulically cleaned with a polypropylene swabbing device to remove dirt, sand, and debris from main.
 - b. If swabbing access and egress points are not provided in the design drawings, it will be the responsibility of the CONTRACTOR to provide and remove temporary access and egress points for the cleaning, as required.
 - c. Passage of cleaning poly swabs through the system shall be constantly monitored, controlled, and all poly swabs entered into the system shall be individually marked and identified so that the

CHAPTER 6

RECLAIMED WATER

Section 650-A

Testing and Inspection for Acceptance

- exiting of the poly swabs from the system can be confirmed.
- d. Cleaning of the system shall be done in conjunction with the initial filling of the system for its hydrostatic test.
 - e. The line to be cleaned shall only be connected to the existing distribution system at a single connection point.
 - f. The CONTRACTOR shall locate and open all new in-line valves beyond the point of connection on the pipeline to be cleaned during the swabbing operation.
 - g. At the receiver or exit point for the poly swab, the CONTRACTOR is responsible for creating a safe environment for collection of debris, water, and the swab. The CONTRACTOR shall provide for the protection of surrounding personnel and property and the safe retrieval of the swab.
 - h. Only PCU personnel shall operate the supply valve from the existing distribution system. Cleaning and flushing shall be accomplished by propelling the swab down the pipeline to the exit point with reclaimed water. Flushing shall continue until the water is completely clear and swab is retrieved.
 - i. Re-apply a series of individual swabs in varying diameters and/or densities as required, to attain proper cleanliness of pipeline.
 - ii. Swabbing speed shall range between two and five feet per second.
 - iii. After the swabbing process, pressure testing and disinfection of the pipe shall be completed in accordance with this MANUAL.

B. Hydrostatic Pressure Testing of Ductile Iron and PVC Pressure Pipe:

Hydrostatic pressure tests shall consist of a pressure test and leakage test for non-butt welded jointed pipes. Hydrostatic tests shall be conducted on all newly laid pressure pipes, joints, and valves including all service lines to the curb stops and fire hydrants assemblies. Testing shall be performed from in-line valve to in-line valve with a depressurized section behind each valve, whenever possible.

- 1. All pipe sections to be pressure tested shall be subjected to a minimum hydrostatic pressure of 150 psi. The duration of each pressure test shall be for a period of two hours. If during the test, the integrity of the tested line is in question, PCU may require a six-hour pressure test. The basic provisions of AWWA C600 shall be applicable.

CHAPTER 6

RECLAIMED WATER

Section 650-A

Testing and Inspection for Acceptance

2. All testing and the quantity of acceptable leakage shall be documented and certified using the appropriate Pressure Test Form.
3. Water supply from the existing distribution system shall be provided through a jumper connection consisting of fittings, a reduced pressure zone cross connection control assembly, and installed as shown in the STANDARD DRAWINGS.
4. Procedure for Pressure Test:

Pipe to be tested shall be slowly filled with water and the specified test pressure shall be applied by means of a pump connected to the pipe in a satisfactory manner. Provisions shall be made to expel air entrapped in the pipe before applying the specified test pressure. To accomplish this, taps shall be made, and appropriate valves installed to ensure bleeding of all air from the main. If defective pipes, fittings, valves, or hydrants are discovered in consequence of this pressure test, all such items shall be removed and replaced by the CONTRACTOR with sound material and the test shall be repeated until satisfactory results are obtained. Provisions of AWWA C600 and C651, where applicable, shall apply.

5. Procedure for Leakage Test:
 - a. After completion of the pressure test, a leakage test shall be conducted to determine the quantity of water lost by leakage under the specified test pressure. Applicable provisions of AWWA C600 shall apply.
 - b. Allowable leakage in gallons per hour for pipeline shall not be greater than that determined by the formula:

$$L = \frac{ND(P)^{1/2}}{7,400}$$

Note:

L - Allowable leakage in gallons per hour.

N - Number of joints in the tested line.

D - Nominal diameter of the pipe in inches.

P - Average test pressure during leakage test in pounds per square inch gauge.

CHAPTER 6

RECLAIMED WATER

Section 650-A

Testing and Inspection for Acceptance

6. Leakage is defined as the quantity of water to be supplied in the newly laid pipe or any valved off section under test, which is necessary to maintain the specified leakage test pressure after the pipe has been filled with water and the air expelled. Should any test of pipe laid disclose leakage greater than that allowed, the CONTRACTOR shall locate and replace or repair the defective joints, pipe or valve until the leakage from subsequent testing is within the specified allowance.
- C. Hydrostatic Pressure Testing of HDPE Pressure Pipe:
1. After installation, the butt welded jointed pipe shall be tested in accordance with this MANUAL with the following modifications:
 - a. Test Duration: The total test time including initial pressurization, initial expansion, and time at test pressure, shall not exceed five hours. If the test is not completed due to leakage, equipment failure, etc., the test section shall be depressurized and allowed to "relax" for a minimum of eight hours before it is brought back up to test pressure.
 - b. Prior to Hydrostatic Pressure Testing Procedure:
 - i. Hydraulically clean the main to be tested with a polypropylene swab (pig) to remove dirt, sand, and debris from the main prior to hydrostatic testing.
 - ii. Insure that main to be tested is restrained against horizontal and vertical movement. Exposing joints only is allowed.
 - c. Hydrostatic Pressure Testing Procedure:
 - i. Fill main slowly with water to remove air.
 - ii. Pressurize up to 1.5 times the Pressure Class of the pipe used at the lowest point of the main being tested.
 - iii. Maintain for 4 hours while adding water as needed in non-monitored amounts as pipe will expand while until pressure.
 - iv. Reduce pressure by 10 psi and monitor for 1 hour.
 - v. Main passes if there are no leaks within 5 percent of the remaining pressure after reduction.
- D. The CONTRACTOR shall furnish all necessary equipment and material, make all taps and furnish all closure pieces in the pipe as required. Equipment to be furnished by the CONTRACTOR shall include graduated containers, pressure gauges, hydraulic forces pumps, and suitable hoses and piping. The PCU representative shall monitor a satisfactory test.

CHAPTER 6

RECLAIMED WATER

Section 650-A

Testing and Inspection for Acceptance

- E. The CONTRACTOR may conduct preliminary hydrostatic tests after the trench has been partially backfilled with the joints left exposed for inspection for informational purposes only. The hydrostatic tests for acceptance shall only be conducted after the trenches have been completely backfilled and compacted as specified. Where any section of pipe is provided with concrete thrust collar, pressure test will not be made until at least five days have elapsed after the thrust collar is installed.
- F. The distribution system piping is to remain isolated and out of service until regulatory clearance is issued for the potable water system and the potable system is subsequently activated.

PART 4 - ACCEPTANCE

4.01 LOCATE WIRE CHECK

- A. The locating wire will be inspected and tested for continuous continuity along the entire length of the main and correct material as specified in the appropriate "Approved Materials Checklist".
- B. Valve locations will be inspected for the proper installation of the locating wire in accordance with the STANDARD DRAWINGS and tested for continuity between the main and the valve.

4.02 VALVES

- A. Valves will be operated to verify a smooth and correct operation, plus the correct direction of opening. PCU shall confirm the location in accordance with the RECORD DRAWINGS and installed in accordance with the STANDARD DRAWINGS.

4.03 VALVE BOXES

- A. Valve boxes will be inspected to ensure they are clear of debris, centered over the operating nut, and installed with a collar as shown in the STANDARD DRAWINGS. The depth of the operating nut will be measured to finished grade to confirm that a riser is installed or not required. Valve boxes shall meet the material standards listed in the appropriate "Approved Materials Checklist".

4.04 SERVICE LINES

- A. Service lines shall be properly identified, free from conflicts with any structure, installed as shown in the STANDARD DRAWINGS, and the

Testing and Inspection for Acceptance

number location and size is as shown on the RECORD DRAWINGS to serve all intended properties. The materials shall be as listed in the appropriate "Approved Materials Checklist".

4.05 AUTOMATIC AIR RELEASE VALVE ASSEMBLIES

- A. Valve assemblies shall be free from any conflicts with any structures, installed in accordance with the STANDARD DRAWINGS, and located as shown on the RECORD DRAWINGS tested to ensure correct operation and confirm materials as listed in the appropriate "Approved Materials Checklist".

CHAPTER 6

RECLAIMED WATER

Section 650-B

Approved Materials Checklist

The use of the following items is mandatory.

Color specification, where applicable, is 204,153,255.

It is understood by the CONTRACTOR that PCU shall reject materials and products not in accordance with this document and the MANUAL at any point in time during construction. Any material or product not contained within this Checklist shall be approved in advance by the Utilities Code Committee in accordance with the provisions of the Utilities Code.

Shop drawings shall be required, and approved by the ENGINEER, for all structures and similar items not contained on this checklist, such as manholes, wet wells, and other castings.

One (1) set of the CONTRACTOR's and ENGINEER's executed shop drawings shall be submitted to PCU for its use. Ordering materials and products not contained within the Approved Materials Checklist is NOT recommended and is done at the CONTRACTOR's sole expense and responsibility.

RECLAIMED WATER CATEGORY 1 OF 9: VALVES AND ACCESSORIES

Automatic Combination Air / Vacuum Release Valves:

<i>ITEM TO BE USED</i>	Manufacturer	Part Number	Comments
	ARI	D-040	Combination
	ARI	S-050	Air Release Only
	Val-Matic	VM-38	Air Release Only – Plant, Facility Use Only
	Val-Matic	VM-45	Air Release Only – Plant, Facility Use Only
	Val-Matic	VM-200C	Combination – Plant, Facility Use Only

CHAPTER 6

RECLAIMED WATER

Section 650-B

Approved Materials Checklist

Air / Vacuum Release Valve Enclosure (Horizontal Venting and Pantone 522-C Purple):

<i>ITEM TO BE USED</i>	Manufacturer	Part Number	Comments
	Water Plus	131632	
	Hydro-Guard	Safety-Guard 15100	

Air / Vacuum Release Valve Vault Frame and Cover:

<i>ITEM TO BE USED</i>	Manufacturer	Part Number	Comments
	US Foundry	USF-679-BK-M	
	Saint-Gobain	Pamrex 36"	Alternative – Not to be used in paved roadways.

Butterfly Valves 12-inch and Larger: (8 mil Epoxy Coated, Lined (AWWA)):

<i>ITEM TO BE USED</i>	Manufacturer	Part Number	Comments
	M & H	4500	
	Mueller/Pratt	Lineseal III / BV (Ground Hog)	
	Val-Matic	2000 Series	to be utilized as directed by PCU.
	DeZurik	BAW Series Butterfly	According to Application.

Gate Valves 16-inch Through 48-inch (Resilient Seated Only with Side/Bevel Gear Actuators):

<i>ITEM TO BE USED</i>	Manufacturer	Part Number	Comments
	American Flow Control	Series 2500	

CHAPTER 6

RECLAIMED WATER

Section 650-B

Approved Materials Checklist

<i>ITEM TO BE USED</i>	Manufacturer	Part Number	Comments
	Mueller	Series A-2361	
	M & H/Kennedy/Clow	Series 7571	

Gate Valves 12-inch and Smaller (Resilient Seated Only):

<i>ITEM TO BE USED</i>	Manufacturer	Part Number	Comments
	American Flow Control	Series 2500	
	M & H/Kennedy/Clow	Series 7571	
	Mueller	Series A-2361	

Tapping Valves (Resilient Seated Only):

<i>ITEM TO BE USED</i>	Manufacturer	Part Number	Comments
	American Flow Control	Series 2500	
	M & H/Kennedy/Clow	Series 4751 and 7571	
	Mueller	Series T-2360 & T-2361	

Silent Check Valve (Master Meter Assemblies)

<i>ITEM TO BE USED</i>	Manufacturer	Part Number	Comments
	Champion Valves, Inc.	SCW – Axial Disc Wafer Silent Check Valve, DI Body	for 2-12 inch

CHAPTER 6

RECLAIMED WATER

Section 650-B

Approved Materials Checklist

Insertion Valves - MJ/Ductile Iron RWGV (in Place of Line Stop/Tapping Sleeve)

<i>ITEM TO BE USED</i>	Manufacturer	Part Number	Comments
	Team Industrial Products	InsertValve	Available 4" through 12"

Test Station Box for Buried Valves:

<i>ITEM TO BE USED</i>	Manufacturer	Part Number	Comments
	Bingham & Taylor	P200NFG	

Valve Boxes with Lids (5¼ -Inch, ASTM A48 30B Cast or Ductile Iron, with "RECLAIMED" cast into the lid top):

<i>ITEM TO BE USED</i>	Manufacturer	Part Number	Comments
	Bingham & Taylor	4905-X, 4905, 4904L	
	Tyler	Series 6850 / 6855	
	American Flow Control*	Trench Adapter Models 1 through 9	* for mains with valve nuts that are 6' or deeper.
	Sigma	VB261, VB262, VB264, VB4650W	
	Mueller	MVB	Use w/ AJBV-4" Locking Bolt
	Star	VB-0002, VB-0004	Heavy Duty Screw or Slip Type

CHAPTER 6

RECLAIMED WATER

Section 650-B

Approved Materials Checklist

RECLAIMED WATER CATEGORY 2 OF 9: SERVICE MATERIALS

Angle Stops Ball Type (1-inch and 2-inch CTS OD Tubing by 5/8-inch by 3/4-inch and 2-inch Meter):

<i>ITEM TO BE USED</i>	Manufacturer	Part Number	Comments
	Ford	BA43-242W, BFA43-777W	
	Mueller	P24258, P24276	
	McDonald	74602B-22	

Angle Stops Ball Type (3/4-inch FIP by 5/8-inch by 3/4-inch Meter):

<i>ITEM TO BE USED</i>	Manufacturer	Part Number	Comments
	Ford	BA13-232W	
	Mueller	B24265R	
	McDonald	74604B	

Brass Service Saddles (Service Saddles Can Be Hinged or Bolt Controlled OD Saddles to be Used on C-900 and IPS OD PVC Pipe):

<i>ITEM TO BE USED</i>	Manufacturer	Part Number	Comments
	Ford	Series S70, S90	
	Mueller	Series S-13000 / H-13000	
	McDonald	3801, 3891	

CHAPTER 6

RECLAIMED WATER

Section 650-B

Approved Materials Checklist

Corporation Stops Ball Type (1-inch and 2-inch with AWWA Iron Pipe Threads Only/Pack Joint Outlet for CTS):

<i>ITEM TO BE USED</i>	Manufacturer	Part Number	Comments
	Ford	FB1000	
	Mueller	P25008	
	McDonald	74701B-22	

Curb Stops Straight Valves (Curb Stop to Be Ball Type, Reduced Port FIP by FIP 3/4-inch by 3/4-inch):

<i>ITEM TO BE USED</i>	Manufacturer	Part Number	Comments
	Ford	B11-233W	
	Mueller	B-20200-R	
	McDonald	76101W	

Curb Stops Straight Valves (Ball Type Compression by Meter, 1-inch and 2-inch CTS OD Tubing by 5/8-inch by 3/4-inch Meter):

<i>ITEM TO BE USED</i>	Manufacturer	Part Number	Comments
	Ford	B43-342W, BF43-777W	
	Mueller	P24350, B24337, B24335	
	McDonald	76101MW-22	

CHAPTER 6

RECLAIMED WATER

Section 650-B

Approved Materials Checklist

Curb Stops Straight Valves (Ball Type Compression by Compression):

<i>ITEM TO BE USED</i>	Manufacturer	Part Number	Comments
	Ford	B44-444W	
	Mueller	P25146	
	McDonald	76100W-22	

Polyethylene Tubing (Blue with UV Protection [SDR-9] 1-inch and 2-inch Only):

<i>ITEM TO BE USED</i>	Manufacturer	Part Number	Comments
	Endot	PE-4710 EndoPure	
	Endot	PE-4710 EndoTrace	Alternative Pipe and Locating Wire Combo
	Charter Plastics	PE-4710	
	ADS	CTS PE4710 PolyFlex	Service Tubing

Service Saddles (Epoxy or Nylon Coated Stainless Steel 18-8-Type 304 Straps, Iron Pipe Threads – 2-inch to be Iron Pipe Threads Controlled OD Saddles to be Used on C-900 and IPS OD PVC Pipe, Double Straps to be 2-inch Minimum Width Each.):

<i>ITEM TO BE USED</i>	Manufacturer	Part Number	Comments
	Ford	Series FC202	
	JCM	Series 406	
	Mueller	DR2S Series	
	McDonald	3835, 3855	

CHAPTER 6

RECLAIMED WATER

Section 650-B

Approved Materials Checklist

<i>ITEM TO BE USED</i>	Manufacturer	Part Number	Comments
	Romac	202N-H	for Use with HDPE Pipe

Y Branch (1-inch by 2-inch):

<i>ITEM TO BE USED</i>	Manufacturer	Part Number	Comments
	Ford	U-48-43	
	Mueller	P-15363N	
	McDonald	08U2M	

Y Branch Assemblies with Angle Ball Valves (1-inch by 2-inch):

<i>ITEM TO BE USED</i>	Manufacturer	Part Number	Comments
	Ford	UVB43-42W	
	Mueller	P-15363-05	
	McDonald	09U2BW	

Meter Boxes w/ Cast Iron Lids (Pantone 522-C Purple, HDPE, with English and Spanish Identification and Warning Wording plus International "Do Not Drink" Symbol on Top):

<i>ITEM TO BE USED</i>	Manufacturer	Part Number	Comments
	Carson PolyPlastic (Oldcastle)	10152026 (Box) 10151019 (Combo)	10154008 (Lid)

CHAPTER 6

RECLAIMED WATER

Section 650-B

Approved Materials Checklist

<i>ITEM TO BE USED</i>	Manufacturer	Part Number	Comments
	DFW Alliance	DFW12005.12-Body (Box) DFW 12005.12.5C (Combo Unit)	DFW12005.5C.LID (Lid)

RECLAIMED WATER CATEGORY 3 OF 9: PIPE MATERIAL

Casing Spacers (All Sizes) Stainless Steel with Vinyl Runners:

<i>ITEM TO BE USED</i>	Manufacturer	Part Number	Comments
	Cascade	Series CCS	
	PSI (GPT)	Series S12/8-G-2	
	CCI	CSS8, CSS12	
	Advanced Products Systems (APS)	SSI8/SSI12/SSIM	

Ductile Iron Pipe Cement Lined (4-inch to 12-inch = PC 350, 16-inch to 20-inch = PC 250, 24-inch = PC 200, 30-inch to 64-inch = PC 150) (DI Flanges as Applicable, AWWA C153):

<i>ITEM TO BE USED</i>	Manufacturer	Part Number	Comments
	American		
	McWane/Clow		
	US Pipe (Forterra)		

CHAPTER 6

RECLAIMED WATER

Section 650-B

Approved Materials Checklist

Paint: Aerial Pipe, Fittings, and Valves (Field and Factory Primer):

<i>ITEM TO BE USED</i>	Manufacturer	Part Number	Comments
	Glidden (Devoe)	Alkyd Metal Primer 4160	
	Porter/International	PP286 U-Primer	
	Tnemec	Series 37H Chem-Primer	
	Wasser	Ferro Clad Primer	

Paint: Finish (Exterior):

<i>ITEM TO BE USED</i>	Manufacturer	Part Number	Comments
	Glidden (Devoe)	Alkyd Industrial Enamel 4308	
	Porter/International	PP2749 Alkyd Gloss	
	Tnemec	Tnemec - Gloss 2H	

PVC (Pantone 522-C Purple) 4-inch Through 12-inch Pipe (AWWA C-900, DR18) and 16-inch and larger pipe (AWWA C-900 or C-909, DR 25):

<i>ITEM TO BE USED</i>	Manufacturer	Part Number	Comments
	Diamond Plastic		
	Ipex		
	JM-Eagle		
	National Pipe		
	NAPCO (Westlake)		North American Pipe Company or Certa-Lok for HDD

CHAPTER 6

RECLAIMED WATER

Section 650-B

Approved Materials Checklist

<i>ITEM TO BE USED</i>	Manufacturer	Part Number	Comments
	Sanderson Piping		

HDPE Pipe DR11 and Fittings (Pantone 522-C Purple Striped):

<i>ITEM TO BE USED</i>	Manufacturer	Part Number	Comments
	Chevron/Phillips	Performance Pipe / ISCO Pipe	PE4710
	Duraline	Polypipe	PE4710
	ENDOT Industries	Endopoly	PE4710
	JM-Eagle		PE4710
	National Pipe		PE4710
	WL Plastics		PE4710
	TUBI		PE4710
	Plasson		PE4710 (Fittings Only)

Reclaimed Water Locating Wire (Single Strand 14-Gauge Solid Copper Wire with Pantone 522-C Purple Colored Insulated Covering):

<i>ITEM TO BE USED</i>	Manufacturer	Part Number	Comments
	Copperhead	Locating Tracer Wire	Alternative

Locating Marker Systems (Reclaimed Water) (Green in Color):

<i>ITEM TO BE USED</i>	Manufacturer	Part Number	Comments
	3M	Scotch Mark EMSII Electronic Marker Purple Locator #1265	Locator, only.

CHAPTER 6

RECLAIMED WATER

Section 650-B

Approved Materials Checklist

<i>ITEM TO BE USED</i>	Manufacturer	Part Number	Comments
	3M	Scotch Marker Electronic Ball Marker #1404-XR	

Curb and Pavement Markers (Pantone 522-C Purple in Color, Imprinted With The Words "POLK COUNTY UTILITIES" And "CALL 811 BEFORE YOU DIG" With "RECLAIMED WATER SERVICE" or "RECLAIMED WATER VALVE" As Applicable):

<i>ITEM TO BE USED</i>	Manufacturer	Part Number	Comments
	Rhino	HideOut Test Station	
	DAS Manufacturing	Reflective Duracast Style (Custom Imprinting)	

RECLAIMED WATER CATEGORY 4 OF 9: PIPE FITTINGS

Expansion Joints:

<i>ITEM TO BE USED</i>	Manufacturer	Part Number	Comments
	EBAA Iron	Flex 900 / Flex-Tend	Below grade @ Tanks
	Metraflex	Metrasphere / Doublesphere	Used @ pumps, above grade.

Couplings:

<i>ITEM TO BE USED</i>	Manufacturer	Part Number	Comments
	EBAA Iron	Series 3800 Restrainer – sleeve included	Includes restraints and tie rods.

CHAPTER 6

RECLAIMED WATER

Section 650-B

Approved Materials Checklist

<i>ITEM TO BE USED</i>	Manufacturer	Part Number	Comments
	Romac	Alpha One-Bolt Coupling, Macro XL	Alpha is restrained, utilized for transition other than AC or VCP. Macro for joining AC piping, only, and requires restraints and tie rods. Alpha coupling ends are acceptable on fittings, valves, hydrants, or other devices per in place of fitting restraint.

Fittings C153 SSB / C110 Flange (Cement Mortar Lined and Asphaltic Coated in Accordance with C104) (Outside Surfaces Shall Be Prime Coated Only If Located Aboveground and Painted):

<i>ITEM TO BE USED</i>	Manufacturer	Part Number	Comments
	American		
	Union/Tyler		
	US Pipe		
	Sigma		
	Star Pipe		
	Serampore Industries (SIP)		

CHAPTER 6

RECLAIMED WATER

Section 650-B

Approved Materials Checklist

Restrained Joints - Ductile Iron Pipe:

<i>ITEM TO BE USED</i>	Manufacturer	Part Number	Comments
	American	Fast Grip Gasket (w/Fastite Piping) Flex Ring Field Flex Ring Lok Ring	
	EBAA Iron Inc.	Mega-lug Series 1100 Series 1700 Bell Restrainer	
	Serampore Industries (SIP)	EZ Grip	
	Sigma	One LOK SLD	
	Sigma	LOK Series PWP	
	Star	Stargrip Series 3000, 3000OS, 3100P & 3100S Retainer Gland Series 600 Series 3200 Adapter Flange Series 200 & 400 Star Flex Series 5000, 5100, & 5200	
	Tyler/Union	Tuf Grip TLD Series 1000, 1000S	for DI Pipe Use
	Tyler/Union	Tuf Grip Dual Wedge Restraint Series 1500	for PVC, DIP, HDPE pipe use

CHAPTER 6

RECLAIMED WATER

Section 650-B

Approved Materials Checklist

Restrained Joints - PVC Pipe:

<i>ITEM TO BE USED</i>	Manufacturer	Part Number	Comments
	EBA Iron Inc.	Mega-lug Series 2000PV Series 1500, 1600, 2200, 2800 Bell Restrainer	
	JCM	610 Sur-Grip Fitting Restrainer 620 Sur-Grip Bell Joint 621 Sur-Grip Bell Joint	
	Uni-Flange/Ford	1350 Bell Restrainer 1360 Bell Restrainer 1390 Bell Restrainer 900 Adapter Flange 1300 Fitting Restrainer 1500 Series	
	Serampore Industries (SIP)	EZ Grip	For PVC
	Sigma	One LOK SLC	
	Sigma	PV LOK Series PVP and PVPF	
	Star	Stargrip PVC Series 4000 PVC Harness Series 1100 & 1200	
	Tyler/Union	Tuf Grip TLP Series 2000, 2000S	for PVC Pipe Use

CHAPTER 6

RECLAIMED WATER

Section 650-B

Approved Materials Checklist

<i>ITEM TO BE USED</i>	Manufacturer	Part Number	Comments
	Tyler/Union	Tuf Grip Dual Wedge Restraint Series 1500	for PVC, DIP, HDPE pipe use
	Tyler/Union	Bell Joint Restraints Series 3000: 32U, 33U	for PVC Pipe Use

Tapping Sleeves (for All Taps on IPS OD PVC pipe, Including Size on Size (18-8 Type 304 Stainless Steel Body, Flange and Bolts), Flange to Accept Standard Tapping Sleeves):

<i>ITEM TO BE USED</i>	Manufacturer	Part Number	Comments
	Ford	Series FTSS	
	JCM	Model 432, 452	
	Mueller	Series H-304 S/S	
	Cascade	CST-EX	
	Total Piping Solutions	Triple Tap	

Tapping Sleeves (Mechanical Joint for All Taps on Cast Iron, Ductile Iron, PVC-900 & AC Pipe, All Taps Including Size on Size):

<i>ITEM TO BE USED</i>	Manufacturer	Part Number	Comments
	American Flow Control	Series 2800	
	Mueller	Series H-615, H-616, H-619	
	JCM	Series 432, 452	
	Total Piping Solutions	Triple Tap	

CHAPTER 6

RECLAIMED WATER

Section 650-B

Approved Materials Checklist

Tapping Sleeves (Fabricated Steel, Mechanical Joint, Fusion Bonded Epoxy Coated):

<i>ITEM TO BE USED</i>	Manufacturer	Part Number	Comments
	JCM	Series 414	

RECLAIMED WATER CATEGORY 5 OF 9: VALVES AND ACCESSORIES (PLANTS AND REMOTE FACILITIES, ONLY)

Knife Gate Valves

<i>ITEM TO BE USED</i>	Manufacturer	Part Number	Comments
	DeZurik	Knife Gate Valve	According to Application

Valve Actuators

<i>ITEM TO BE USED</i>	Manufacturer	Part Number	Comments
	Beck	Model 11	Remote Indication or Position Display According to Application
	Auma	SA	Remote Indication or AumaMatic, According to Application

Hydraulically Operated Control Valves (Pressure Reducing/Sustaining Valves):

<i>ITEM TO BE USED</i>	Manufacturer	Part Number	Comments
	Cla-Val		Model or Series based on field application.

CHAPTER 6

RECLAIMED WATER

Section 650-B

Approved Materials Checklist

<i>ITEM TO BE USED</i>	Manufacturer	Part Number	Comments
	OCV		Model or Series based on field application.
	Watts		Model or Series based on field application.

Pressure Gauges:

<i>ITEM TO BE USED</i>	Manufacturer	Part Number	Comments
	Ashcroft	1279	0-60 PSI
	Ametek	Solfrunt 1980	0-60 PSI
	Wika	XSEL	0-60 PSI

Pressure Gauges (Diaphragm Seals)

<i>ITEM TO BE USED</i>	Manufacturer	Part Number	Comments
	Ashcroft	Type 201	

Pressure Indicating Transmitters:

<i>ITEM TO BE USED</i>	Manufacturer	Part Number	Comments
	Rosemount	2051	See Section 516 (Wastewater)
	Siemens	Sitrans P	See Section 516 (Wastewater)

CHAPTER 6

RECLAIMED WATER

Section 650-B

Approved Materials Checklist

Pressure Transmitter (Non-Indicating, Clean/Potable Water)

<i>ITEM TO BE USED</i>	Manufacturer	Part Number	Comments
	Keller	Econoline	See Section 516 (Wastewater)
	Ashcroft	A2	See Section 516 (Wastewater)
	Wika	S-10	See Section 516 (Wastewater)

RECLAIMED WATER CATEGORY 6 OF 9: PUMPS, CHEMICAL FEED SYSTEMS

Vertical Turbine

<i>ITEM TO BE USED</i>	Manufacturer	Part Number	Comments
	Goulds		
	Flowserve	VIC, VIT, SMVT, or DWT	based on application.
	Deming		(AKA: Process Systems, Inc.)
	National		

Centrifugal/Split Case/End Suction

<i>ITEM TO BE USED</i>	Manufacturer	Part Number	Comments
	Aurora		
	Flowserve		
	Goulds		

CHAPTER 6

RECLAIMED WATER

Section 650-B

Approved Materials Checklist

Chemical Pumps

<i>ITEM TO BE USED</i>	Manufacturer	Part Number	Comments
	Prominent		Appropriate series based on flow rate. Degassing heads for NaOCl.

Skid, Shelf Mounted Feed Systems

<i>ITEM TO BE USED</i>	Manufacturer	Part Number	Comments
	Blue Planet w/ Prominent Pumps		Utilize "Polk County" junction box with hour meter/operating indication.

Chemical Tanks

<i>ITEM TO BE USED</i>	Manufacturer	Part Number	Comments
	Snyder	Captor/Dual Containment	HDLPE with NaOCl Resin
	Poly Processing Co.	Saf-T tank,	XLPE with OR 1000 Inner Coating

RECLAIMED WATER CATEGORY 7 OF 9: TANKS AND GENERATORS

Pre-stressed Concrete Tanks

<i>ITEM TO BE USED</i>	Manufacturer	Part Number	Comments
	Crom		
	Pre-con		

CHAPTER 6

RECLAIMED WATER

Section 650-B

Approved Materials Checklist

Standby Power Generators

<i>ITEM TO BE USED</i>	Manufacturer	Part Number	Comments
	Caterpillar		
	Cummings		
	Kohler		

Fuel Tanks (Stand-alone)

<i>ITEM TO BE USED</i>	Manufacturer	Part Number	Comments
	Convault		Pneumercator level/leak detection systems also required. LC 1000 w/ LS600 and LS610.
	Modern Welding		Pneumercator level/leak detection systems also required. LC 1000 w/ LS600 and LS610.
	Phoenix		Pneumercator level/leak detection systems also required. LC 1000 w/ LS600 and LS610.

RECLAIMED WATER CATEGORY 8 OF 9: FLOW METERS

Flow Meters (Full Profile Insertion Electromagnetic)

<i>ITEM TO BE USED</i>	Manufacturer	Part Number	Comments
	McCrometer	FPI Mag 394L Bidirectional w/ M Series Transmitter	Insertion with 2" full-port ball valve

CHAPTER 6

RECLAIMED WATER

Section 650-B

Approved Materials Checklist

RECLAIMED WATER CATEGORY 9 OF 9: ELECTRICAL

VFDs, Relays, Breakers

<i>ITEM TO BE USED</i>	Manufacturer	Part Number	Comments
	Schneider-Electric	Square D	See Chapter 7 for specific requirements.

Security/Surveillance System

<i>ITEM TO BE USED</i>	Manufacturer	Part Number	Comments
	Axis		Camera/Equipment
	Bosch		Camera/Equipment
	Pelco		Camera/Equipment
	Exacqvision		Software

CHAPTER 6

RECLAIMED WATER

Section 650-C

**Reclaimed Water System Hydrostatic Pressure Test Report
 (PVC and Ductile Iron Pipe)**

Project:

PCU Project No.:

Procedures for conducting this test shall be in strict conformance with AWWA standard C600, latest revision. Maximum allowable leakage shall be: $L = \frac{ND(P)^{1/2}}{7,400}$

Where:

L = maximum allowable leakage, measured in gallons per hour

N = number of joints in the tested line (where a pipe joins a pipe or a pipe joins a fitting)

D = nominal diameter of pipe, measured in inches

P = test gauge pressure, measured in pounds per square inch (minimally 150 psi)

(For a 2-hour test at 150 psi, equation simplifies to: $L = ND \times 0.00331$)

TESTING PARAMETERS & SYSTEM INFORMATION

Test Pressure (minimally 150 psi):	psi		
Beginning Test Pressure:	psi	Ending Test Pressure:	psi
Test Duration (minimally 2 hours):	Hours:		
Date of Test:			
Time at Start of Test:	Time at End of Test:		
Test Segment Location:			

Pipe Type	Diameter, inches	Length, feet	Number of joints	Max. Leakage for 2 Hour Test, gallons
Total Maximum Allowable Leakage, gallons:				
Total Actual Leakage, gallons:				

CONTRACTOR & INSPECTOR PERSONNEL INFORMATION

	Contractor	Inspector
Signature:		
Printed Name:		
Company Name:		
Phone Number:		
Date:		

CHAPTER 6

RECLAIMED WATER

Section 650-D

**Reclaimed Water System Hydrostatic Pressure Test Report
 (HDPE Pipe)**

Project:

PCU Project No.:

Procedures for conducting this test shall be in accordance with ASTM F 2164 and AWWA Standard C600, latest revision, where applicable. Pneumatic Testing is strictly prohibited.

Prior to Hydrostatic Pressure Testing Procedure:

- 1).. Flush main with a minimum velocity of 3 fps to clear foreign materials.
- 2).. Insure that main to be tested is restrained against horizontal and vertical movement.
 Exposing joints only is allowed.

Hydrostatic Pressure Testing Procedure:

- 1).. Fill main slowly with water to remove air.
- 2).. Pressurize up to 1.5 times the Pressure Class of the pipe used at the lowest point of the main being tested.
- 3).. Maintain for 4 hours while adding water as needed in non-monitored amounts as pipe will expand while until pressure.
- 4).. Reduce pressure by 10 psi and monitor for 1 hour.
- 5).. Main passes if there are no leaks within 5 percent of the remaining pressure after reduction.

Disinfection is to be performed in accordance with AWWA Standard C651.

TESTING PARAMETERS & SYSTEM INFORMATION

Calculated Test Pressure:	psi		
Beginning Test Pressure:	psi	Ending Test Pressure:	psi
Test Duration (minimally 5 hours):	Hours:		
Date of Test:			
Time at Start of Test:		Time at End of Test:	

Diameter, inches	Length, feet	Pressure Class, psi	Test Segment Location

CONTRACTOR & INSPECTOR PERSONNEL INFORMATION

	Contractor	Inspector
Signature:		
Printed Name:		
Company Name:		
Phone Number:		

CHAPTER 6

RECLAIMED WATER

Section 650-E

Reclaimed Water System Pigging Report

Project:

PCU Project No.:

Procedures for pigging the system shall be in strict conformance with the Polk County Utilities Standards and Specifications Manual.

PIGGING PARAMETERS & SYSTEM INFORMATION

Date of Pigging:	
Time at Start of Pigging:	Time at End of Pigging:
Pigged Segment Location:	
Pig Outside Diameter:	Pig's Maximum % Compression of Full Size:
Pig Exterior Material Composition:	Pig Interior Material Composition:
Pig Manufacturer:	

Pipe Type	Diameter, inches	Length, feet	Number of Times Pigged	Estimated Amount of Water Used for Pigging, gallons
Total Estimated Amount of Water Used for Pigging, gallons:				
Total Actual Amount of Water Used for Pigging, gallons:				

CONTRACTOR & INSPECTOR PERSONNEL INFORMATION

	Contractor	Inspector
Signature:		
Printed Name:		
Company Name:		
Phone Number:		
Date:		

CHAPTER 6

RECLAIMED WATER

Section 650-F

RECLAIMED WATER SCHEDULE OF VALUES

Date:

Contractor:

Project:

PCU Project No.:

Item No.	Item Description	Qty.	Unit	Unit Cost (\$)	Extended Cost (\$)
1	Single Service, Long				
2	Single Service, Short				
3	Double Service, Long				
4	Double Service, Short				
5	Blow-Off Assembly, Complete				
6					
7					
8					
9					
10	4" PVC, AWWA C-900, DR 18, Purple				
11	4" DIP, Pressure Class 350, Epoxy-Lined, Bituminous Coated				
12	4" Gate Valve Assembly, Complete				
13	4" 11 ¼ Degree Bend, DI, C153, Epoxy-Lined, Bituminous Coated				
14	4" 22 ½ Degree Bend, DI, C153, Epoxy-Lined, Bituminous Coated				
15	4" 45 Degree Bend, DI, C153, Epoxy-Lined, Bituminous Coated				
16	4" 90 Degree Bend, DI, C153, Epoxy-Lined, Bituminous Coated				
17	4" Tee, DI, C153, Epoxy-Lined, Bituminous Coated				
18	4" Cross, DI, C153, Epoxy-Lined, Bituminous Coated				
19					
20	4" HDPE				
21					
22	6" PVC, AWWA C-900, DR 18, Purple				

CHAPTER 6

RECLAIMED WATER

Section 650-F

RECLAIMED WATER SCHEDULE OF VALUES

Item No.	Item Description	Qty.	Unit	Unit Cost (\$)	Extended Cost (\$)
23	6" DIP, Pressure Class 350, Epoxy-Lined, Bituminous Coated				
24	6" Gate Valve Assembly, Complete				
25	6" 11 ¼ Degree Bend, DI, C153, Epoxy-Lined, Bituminous Coated				
26	6" 22 ½ Degree Bend, DI, C153, Epoxy-Lined, Bituminous Coated				
27	6" 45 Degree Bend, DI, C153, Epoxy-Lined, Bituminous Coated				
28	6" 90 Degree Bend, DI, C153, Epoxy-Lined, Bituminous Coated				
29	6" Tee, DI, C153, Epoxy-Lined, Bituminous Coated				
30	6" Cross, DI, C153, Epoxy-Lined, Bituminous Coated				
31					
32	6" HDPE				
33					
34	8" PVC, AWWA C-900, DR 18, Purple				
35	8" DIP, Pressure Class 350, Epoxy-Lined, Bituminous Coated				
36	8" Gate Valve Assembly, Complete				
37	8" 11 ¼ Degree Bend, DI, C153, Epoxy-Lined, Bituminous Coated				
38	8" 22 ½ Degree Bend, DI, C153, Epoxy-Lined, Bituminous Coated				
39	8" 45 Degree Bend, DI, C153, Epoxy-Lined, Bituminous Coated				
40	8" 90 Degree Bend, DI, C153, Epoxy-Lined, Bituminous Coated				
41	8" Tee, DI, C153, Epoxy-Lined, Bituminous Coated				
42	8" Cross, DI, C153, Epoxy-Lined, Bituminous Coated				
43					

CHAPTER 6

RECLAIMED WATER

Section 650-F

RECLAIMED WATER SCHEDULE OF VALUES

Item No.	Item Description	Qty.	Unit	Unit Cost (\$)	Extended Cost (\$)
44	8" HDPE				
45					
46	10" PVC, AWWA C-900, DR 18, Purple				
47	10" DIP, Pressure Class 350 Epoxy-Lined, Bituminous Coated				
48	10" Gate Valve Assembly, Complete				
49	10" 11 ¼ Degree Bend, DI, C153, Epoxy-Lined, Bituminous Coated				
50	10" 22 ½ Degree Bend, DI, C153, Epoxy-Lined, Bituminous Coated				
51	10" 45 Degree Bend, DI, C153, Epoxy-Lined, Bituminous Coated				
52	10" 90 Degree Bend, DI, C153, Epoxy-Lined, Bituminous Coated				
53	10" Tee, DI, C153, Epoxy-Lined, Bituminous Coated				
54	10" Cross, DI, C153, Epoxy-Lined, Bituminous Coated				
55					
56	10" HDPE				
57					
58	12" PVC, AWWA C-900, DR 18, Purple				
59	12" DIP, Pressure Class 350, Epoxy-Lined, Bituminous Coated				
60	12" Gate Valve Assembly, Complete				
61	12" 11 ¼ Degree Bend, DI, C153, Epoxy-Lined, Bituminous Coated				
62	12" 22 ½ Degree Bend, DI, C153, Epoxy-Lined, Bituminous Coated				

CHAPTER 6

RECLAIMED WATER

Section 650-F

RECLAIMED WATER SCHEDULE OF VALUES

Item No.	Item Description	Qty.	Unit	Unit Cost (\$)	Extended Cost (\$)
63	12" 45 Degree Bend, DI, C153, Epoxy-Lined, Bituminous Coated				
64	12" 90 Degree Bend, DI, C153, Epoxy-Lined, Bituminous Coated				
65	12" Tee, DI, C153, Epoxy-Lined, Bituminous Coated				
66	12" Cross, DI, C153, Epoxy-Lined, Bituminous Coated				
67					
68	12" HDPE				
69					
70	16" PVC, AWWA C-905, DR 25, Purple				
71	16" DIP, Pressure Class 350, Epoxy-Lined, Bituminous Coated				
72	16" Gate Valve Assembly, Complete				
73	16" 11 ¼ Degree Bend, DI, C153, Epoxy-Lined, Bituminous Coated				
74	16" 22 ½ Degree Bend, DI, C153, Epoxy-Lined, Bituminous Coated				
75	16" 45 Degree Bend, DI, C153, Epoxy-Lined, Bituminous Coated				
76	16" 90 Degree Bend, DI, C153, Epoxy-Lined, Bituminous Coated				
77	16" Tee, DI, C153, Epoxy-Lined, Bituminous Coated				
78	16" Cross, DI, C153, Epoxy-Lined, Bituminous Coated				
79					
80	16" HDPE				

Total Constructed Value: \$

Reviewer:

Date:

Comments